



# High Pressure Equipment

## Medium Pressure Valves, Fittings and Tubing 20,000 psi service

High Pressure Equipment Company has developed a line of Medium Pressure products to assure safe and easy plumbing through 20,000 psi. These needle valves, fittings, line filters, check valves, safety heads, rupture discs, anti-vibration gland assemblies, tubing and nipples are engineered to the highest standards of repeatable quality. The reliable performance of these products has made HiP one of the world's leading suppliers of elevated pressure components.

Medium Pressure components use a compact coned-and-threaded connection which permits the larger bore sizes and increased flow rates common in this pressure class. Medium Pressure valves are available in  $\frac{1}{4}$ ",  $\frac{3}{8}$ ",  $\frac{9}{16}$ ",  $\frac{3}{4}$ ", 1" and  $1\frac{1}{2}$ " O.D. tubing sizes and six patterns to satisfy widely varied requirements. A line of fittings is available to facilitate adapting to Taper Seal, High Pressure or other threaded pipe systems.



### Index

|                                 |       |
|---------------------------------|-------|
| 20,000 psi Valves*              | 29-30 |
| Valve Options                   | 31    |
| Fittings                        | 32    |
| Unions, Bulkheads & Caps        | 33    |
| Line Filters & Check Valves     | 34    |
| Safety Heads                    | 35    |
| Rupture Discs                   | 36    |
| Anti-Vibration Gland Assemblies | 37    |
| Tubing                          | 38    |
| Coned & Threaded Nipples        | 38    |
| Connection Details              | 39    |

\*Note: 10,000 psi large orifice is offered in  $\frac{3}{4}$ " and 1" size.



**Medium Pressure (coned & threaded)** type connections for  $\frac{1}{4}$ ",  $\frac{3}{8}$ ",  $\frac{9}{16}$ ",  $\frac{3}{4}$ ", 1" and  $1\frac{1}{2}$ " O.D. tubing.

**Non-rotating slotted stems** are standard on LF4, LF6 and LF9 for on-off service and ensure long life on valve seats. Regulating tip stems are available for all valves at no additional cost, add - REG to part number.

**Glands and collars** for tubing are supplied with each valve unless otherwise requested (glands and collars shown on pages 32 and 39).

**Materials** include high tensile type 316 stainless steel bodies and hardened 17-4PH stainless steel lower section stems.  $\frac{1}{2}$ " O.D. valves are constructed of 2205 duplex.

**Packing** is Teflon (450°F) standard with optional Viton (350°F), BUNA-N (200°F) and Grafoil (800°F) available at no additional cost.

**Air operators** for remote control operation are available for all valves. (Refer to Air Operator section of catalog for additional data).

**Extreme temperatures** can be accommodated by using extended stuffing boxes (See Valve Options, page 31).

4

**Valve Features**

- Non-rotating slotted stem design (standard for LF4, LF6 and LF9)
- Packing below stem threads
- Positive gland lock device
- Tube sizes  $\frac{1}{4}$ " through  $1\frac{1}{2}$ "
- Type 316 ss high tensile bodies
- No stem adjustment needed – LF4, LF6 and LF9
- Black T-handles or choice of 4 colors – LF4, LF6 and LF9
- 316 ss handles LF12, LF16 and LF24

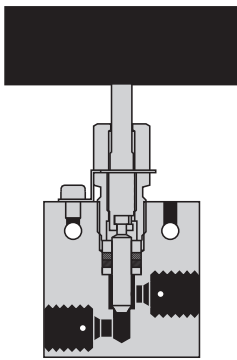

LF4 ( $\frac{1}{4}$ " ) and LF6 ( $\frac{3}{8}$ " )

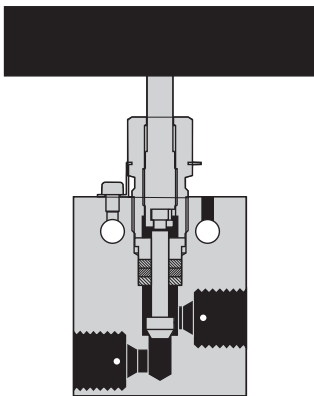

LF9 ( $\frac{9}{16}$ " )

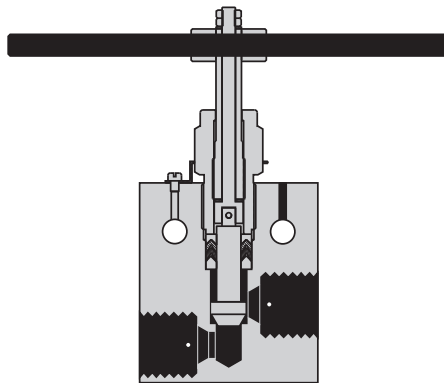

LF12 ( $\frac{3}{4}$ " ) and LF16 (1" )\*

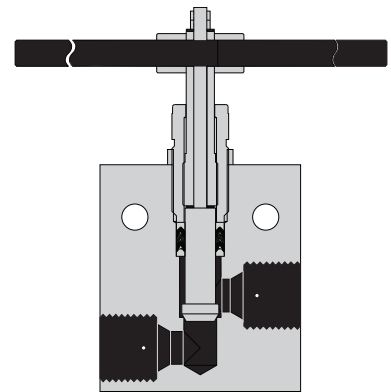

LF24 ( $1\frac{1}{2}$ " ) (Rated to 15,000 psi)

\* Note: 10,000 psi large orifice is offered in  $\frac{3}{4}$ " and 1" size.

# Medium Pressure Valves

## Two Way Straight Valves

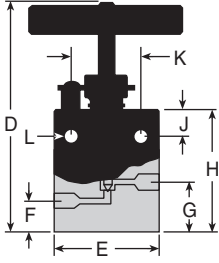

| Tubing      | Catalog No. | psi    | Conn. | Orifice                          | Cv   | D                                | E                               | F      | G                                 | H                               | J      | K                               | L                                | Thickness                       |
|-------------|-------------|--------|-------|----------------------------------|------|----------------------------------|---------------------------------|--------|-----------------------------------|---------------------------------|--------|---------------------------------|----------------------------------|---------------------------------|
| 1/4" O.D.   | 20-11LF4    | 20,000 | LF4   | 1/8"                             | 0.17 | 4 <sup>3</sup> / <sub>16</sub> " | 2"                              | 3/8"   | 1 <sup>3</sup> / <sub>16</sub> "  | 2"                              | 3/8"   | 1 1/4"                          | 7/32"                            | 3/4"                            |
| 3/8" O.D.   | 20-11LF6    | 20,000 | LF6   | 1 <sup>3</sup> / <sub>64</sub> " | 0.45 | 4 <sup>3</sup> / <sub>16</sub> " | 2"                              | 3/8"   | 1 <sup>3</sup> / <sub>16</sub> "  | 2"                              | 3/8"   | 1 1/4"                          | 7/32"                            | 3/4"                            |
| 9/16" O.D.  | 20-11LF9    | 20,000 | LF9   | 5/16"                            | 1.12 | 6 <sup>1</sup> / <sub>8</sub> "  | 2 1/2"                          | 1/2"   | 1 1/8"                            | 2 <sup>7</sup> / <sub>8</sub> " | 1 1/2" | 1 <sup>3</sup> / <sub>8</sub> " | 1 <sup>1</sup> / <sub>32</sub> " | 1"                              |
| 3/4" O.D.   | 20-11LF12   | 20,000 | LF12  | 7/16"                            | 2.29 | 7"                               | 3"                              | 3/4"   | 1 1/2"                            | 3 <sup>3</sup> / <sub>4</sub> " | 5/8"   | 1 <sup>3</sup> / <sub>4</sub> " | 7/16"                            | 1 <sup>3</sup> / <sub>8</sub> " |
| 3/4" O.D.   | 10-11LF12   | 10,000 | LF12  | 3 <sup>3</sup> / <sub>64</sub> " | 3.65 | 7"                               | 3"                              | 3/4"   | 1 1/2"                            | 3 <sup>3</sup> / <sub>4</sub> " | 5/8"   | 1 <sup>3</sup> / <sub>4</sub> " | 7/16"                            | 1 <sup>3</sup> / <sub>8</sub> " |
| 1" O.D.     | 20-11LF16   | 20,000 | LF16  | 9/16"                            | 3.86 | 8 <sup>2</sup> / <sub>16</sub> " | 4 <sup>1</sup> / <sub>8</sub> " | 7/8"   | 1 <sup>13</sup> / <sub>16</sub> " | 4 <sup>5</sup> / <sub>8</sub> " | 1 1/8" | 2 1/2"                          | 9/16"                            | 1 <sup>3</sup> / <sub>4</sub> " |
| 1" O.D.     | 10-11LF16   | 10,000 | LF16  | 1 <sup>1</sup> / <sub>16</sub> " | 5.91 | 8 <sup>2</sup> / <sub>16</sub> " | 4 <sup>1</sup> / <sub>8</sub> " | 7/8"   | 1 <sup>13</sup> / <sub>16</sub> " | 4 <sup>5</sup> / <sub>8</sub> " | 1 1/8" | 2 1/2"                          | 9/16"                            | 1 <sup>3</sup> / <sub>4</sub> " |
| 1 1/2" O.D. | 15-11LF24   | 15,000 | LF24  | 1 <sup>5</sup> / <sub>16</sub> " | —    | 9 <sup>5</sup> / <sub>16</sub> " | 5 <sup>1</sup> / <sub>4</sub> " | 1 1/4" | 2 <sup>3</sup> / <sub>4</sub> "   | 6 1/2"                          | 1 1/2" | 3 <sup>3</sup> / <sub>4</sub> " | 3/4"                             | 2 1/4"                          |

## Two Way Angle Valves

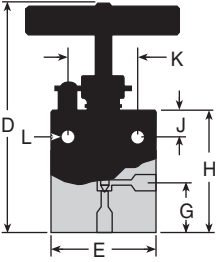

| Tubing      | Catalog No. | psi    | Conn. | Orifice                          | Cv    | D                                 | E                               | F | G                                | H                                | J      | K                               | L                                | Thickness                       |
|-------------|-------------|--------|-------|----------------------------------|-------|-----------------------------------|---------------------------------|---|----------------------------------|----------------------------------|--------|---------------------------------|----------------------------------|---------------------------------|
| 1/4" O.D.   | 20-12LF4    | 20,000 | LF4   | 1/8"                             | 0.255 | 4 <sup>13</sup> / <sub>16</sub> " | 2"                              | — | 1 1/4"                           | 2 <sup>1</sup> / <sub>16</sub> " | 3/8"   | 1 1/4"                          | 7/32"                            | 3/4"                            |
| 3/8" O.D.   | 20-12LF6    | 20,000 | LF6   | 1 <sup>3</sup> / <sub>64</sub> " | 0.675 | 4 <sup>13</sup> / <sub>16</sub> " | 2"                              | — | 1 1/4"                           | 2 <sup>1</sup> / <sub>16</sub> " | 3/8"   | 1 1/4"                          | 7/32"                            | 3/4"                            |
| 9/16" O.D.  | 20-12LF9    | 20,000 | LF9   | 5/16"                            | 1.68  | 6 <sup>5</sup> / <sub>8</sub> "   | 2 1/2"                          | — | 1 <sup>5</sup> / <sub>8</sub> "  | 3 <sup>3</sup> / <sub>8</sub> "  | 1 1/2" | 1 <sup>3</sup> / <sub>8</sub> " | 1 <sup>1</sup> / <sub>32</sub> " | 1"                              |
| 3/4" O.D.   | 20-12LF12   | 20,000 | LF12  | 7/16"                            | 3.435 | 7 1/2"                            | 3"                              | — | 2"                               | 4 1/4"                           | 5/8"   | 1 <sup>3</sup> / <sub>4</sub> " | 7/16"                            | 1 <sup>3</sup> / <sub>8</sub> " |
| 3/4" O.D.   | 10-12LF12   | 10,000 | LF12  | 3 <sup>3</sup> / <sub>64</sub> " | 5.475 | 7 1/2"                            | 3"                              | — | 2"                               | 4 1/4"                           | 5/8"   | 1 <sup>3</sup> / <sub>4</sub> " | 7/16"                            | 1 <sup>3</sup> / <sub>8</sub> " |
| 1" O.D.     | 20-12LF16   | 20,000 | LF16  | 9/16"                            | 5.79  | 9 <sup>3</sup> / <sub>8</sub> "   | 4 <sup>1</sup> / <sub>8</sub> " | — | 2 <sup>9</sup> / <sub>16</sub> " | 5 <sup>1</sup> / <sub>16</sub> " | 1 1/8" | 2 1/2"                          | 9/16"                            | 1 <sup>3</sup> / <sub>4</sub> " |
| 1" O.D.     | 10-12LF16   | 10,000 | LF16  | 1 <sup>1</sup> / <sub>16</sub> " | 8.865 | 9 <sup>3</sup> / <sub>8</sub> "   | 4 <sup>1</sup> / <sub>8</sub> " | — | 2 <sup>9</sup> / <sub>16</sub> " | 5 <sup>1</sup> / <sub>16</sub> " | 1 1/8" | 2 1/2"                          | 9/16"                            | 1 <sup>3</sup> / <sub>4</sub> " |
| 1 1/2" O.D. | 15-12LF24   | 15,000 | LF24  | 1 <sup>5</sup> / <sub>16</sub> " | —     | 9 <sup>6</sup> / <sub>16</sub> "  | 5 <sup>1</sup> / <sub>4</sub> " | — | 3"                               | 6 <sup>3</sup> / <sub>4</sub> "  | 1 1/2" | 3 <sup>3</sup> / <sub>4</sub> " | 3/4"                             | 2 1/4"                          |

## Three Way Valves / Two Pressure Connections

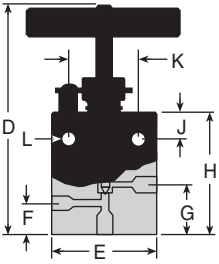

| Tubing     | Catalog No. | psi    | Connection | Orifice                          | D                               | E                               | F                               | G                                | H                               | J      | K                               | L                                | Thickness                       |
|------------|-------------|--------|------------|----------------------------------|---------------------------------|---------------------------------|---------------------------------|----------------------------------|---------------------------------|--------|---------------------------------|----------------------------------|---------------------------------|
| 1/4" O.D.  | 20-13LF4    | 20,000 | LF4        | 1/8"                             | 5"                              | 2"                              | 1"                              | 1 <sup>7</sup> / <sub>16</sub> " | 2 <sup>5</sup> / <sub>8</sub> " | 3/8"   | 1 1/4"                          | 7/32"                            | 3/4"                            |
| 3/8" O.D.  | 20-13LF6    | 20,000 | LF6        | 1 <sup>3</sup> / <sub>64</sub> " | 5"                              | 2"                              | 1"                              | 1 <sup>7</sup> / <sub>16</sub> " | 2 <sup>5</sup> / <sub>8</sub> " | 3/8"   | 1 1/4"                          | 7/32"                            | 3/4"                            |
| 9/16" O.D. | 20-13LF9    | 20,000 | LF9        | 5/16"                            | 6 <sup>1</sup> / <sub>8</sub> " | 2 1/2"                          | 1 1/4"                          | 1 <sup>7</sup> / <sub>8</sub> "  | 3 <sup>5</sup> / <sub>8</sub> " | 1 1/2" | 1 <sup>3</sup> / <sub>8</sub> " | 1 <sup>1</sup> / <sub>32</sub> " | 1"                              |
| 3/4" O.D.  | 20-13LF12   | 20,000 | LF12       | 7/16"                            | 7 1/8"                          | 3"                              | 2 <sup>5</sup> / <sub>8</sub> " | 2 <sup>3</sup> / <sub>8</sub> "  | 4 <sup>5</sup> / <sub>8</sub> " | 5/8"   | 1 <sup>3</sup> / <sub>4</sub> " | 7/16"                            | 1 <sup>3</sup> / <sub>8</sub> " |
| 3/4" O.D.  | 10-13LF12   | 10,000 | LF12       | 3 <sup>3</sup> / <sub>64</sub> " | 7 1/8"                          | 3"                              | 2 <sup>5</sup> / <sub>8</sub> " | 2 <sup>3</sup> / <sub>8</sub> "  | 4 <sup>5</sup> / <sub>8</sub> " | 5/8"   | 1 <sup>3</sup> / <sub>4</sub> " | 7/16"                            | 1 <sup>3</sup> / <sub>8</sub> " |
| 1" O.D.    | 20-13LF16   | 20,000 | LF16       | 9/16"                            | 9 <sup>3</sup> / <sub>4</sub> " | 4 <sup>1</sup> / <sub>8</sub> " | 2 <sup>1</sup> / <sub>8</sub> " | 3 <sup>1</sup> / <sub>16</sub> " | 5 <sup>7</sup> / <sub>8</sub> " | 1 1/8" | 2 1/2"                          | 9/16"                            | 1 <sup>3</sup> / <sub>4</sub> " |
| 1" O.D.    | 10-13LF16   | 10,000 | LF16       | 1 <sup>1</sup> / <sub>16</sub> " | 9 <sup>3</sup> / <sub>4</sub> " | 4 <sup>1</sup> / <sub>8</sub> " | 2 <sup>1</sup> / <sub>8</sub> " | 3 <sup>1</sup> / <sub>16</sub> " | 5 <sup>7</sup> / <sub>8</sub> " | 1 1/8" | 2 1/2"                          | 9/16"                            | 1 <sup>3</sup> / <sub>4</sub> " |

## Three Way Valves / One Pressure Connection

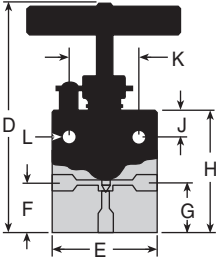

| Tubing     | Catalog No. | psi    | Connection | Orifice                          | D                                 | E                               | F                               | G                               | H                                | J      | K                               | L                                | Thickness                       |
|------------|-------------|--------|------------|----------------------------------|-----------------------------------|---------------------------------|---------------------------------|---------------------------------|----------------------------------|--------|---------------------------------|----------------------------------|---------------------------------|
| 1/4" O.D.  | 20-14LF4    | 20,000 | LF4        | 1/8"                             | 4 <sup>13</sup> / <sub>16</sub> " | 2"                              | 1 1/4"                          | 1 1/4"                          | 2 <sup>1</sup> / <sub>16</sub> " | 3/8"   | 1 1/4"                          | 7/32"                            | 3/4"                            |
| 3/8" O.D.  | 20-14LF6    | 20,000 | LF6        | 1 <sup>3</sup> / <sub>64</sub> " | 4 <sup>13</sup> / <sub>16</sub> " | 2"                              | 1 1/4"                          | 1 1/4"                          | 2 <sup>1</sup> / <sub>16</sub> " | 3/8"   | 1 1/4"                          | 7/32"                            | 3/4"                            |
| 9/16" O.D. | 20-14LF9    | 20,000 | LF9        | 5/16"                            | 6 <sup>5</sup> / <sub>8</sub> "   | 2 1/2"                          | 1 <sup>9</sup> / <sub>8</sub> " | 1 <sup>5</sup> / <sub>8</sub> " | 3 <sup>3</sup> / <sub>8</sub> "  | 1 1/2" | 1 <sup>3</sup> / <sub>8</sub> " | 1 <sup>1</sup> / <sub>32</sub> " | 1"                              |
| 3/4" O.D.  | 20-14LF12   | 20,000 | LF12       | 7/16"                            | 7 1/2"                            | 3"                              | 2"                              | 2"                              | 4 1/4"                           | 5/8"   | 1 <sup>3</sup> / <sub>4</sub> " | 7/16"                            | 1 <sup>3</sup> / <sub>8</sub> " |
| 3/4" O.D.  | 10-14LF12   | 10,000 | LF12       | 3 <sup>3</sup> / <sub>64</sub> " | 7 1/2"                            | 3"                              | 2"                              | 2"                              | 4 1/4"                           | 5/8"   | 1 <sup>3</sup> / <sub>4</sub> " | 7/16"                            | 1 <sup>3</sup> / <sub>8</sub> " |
| 1" O.D.    | 20-14LF16   | 20,000 | LF16       | 9/16"                            | 9 <sup>3</sup> / <sub>8</sub> "   | 4 <sup>1</sup> / <sub>8</sub> " | 2 <sup>5</sup> / <sub>8</sub> " | 2 <sup>5</sup> / <sub>8</sub> " | 5 <sup>7</sup> / <sub>16</sub> " | 1 1/8" | 2 1/2"                          | 9/16"                            | 1 <sup>3</sup> / <sub>4</sub> " |
| 1" O.D.    | 10-14LF16   | 10,000 | LF16       | 1 <sup>1</sup> / <sub>16</sub> " | 9 <sup>3</sup> / <sub>8</sub> "   | 4 <sup>1</sup> / <sub>8</sub> " | 2 <sup>5</sup> / <sub>8</sub> " | 2 <sup>5</sup> / <sub>8</sub> " | 5 <sup>7</sup> / <sub>16</sub> " | 1 1/8" | 2 1/2"                          | 9/16"                            | 1 <sup>3</sup> / <sub>4</sub> " |

## Three Way / Two Stem Connection Valves

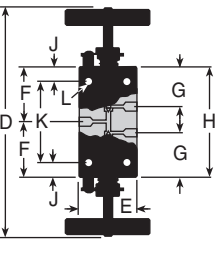

| Tubing     | Catalog No. | psi    | Connection | Orifice                          | D                                 | E                               | F                                 | G                                 | H                               | J      | K                               | L                                | Thickness                       |
|------------|-------------|--------|------------|----------------------------------|-----------------------------------|---------------------------------|-----------------------------------|-----------------------------------|---------------------------------|--------|---------------------------------|----------------------------------|---------------------------------|
| 1/4" O.D.  | 20-15LF4    | 20,000 | LF4        | 1/8"                             | 5 <sup>3</sup> / <sub>4</sub> "   | 2"                              | 1 <sup>11</sup> / <sub>16</sub> " | 1 <sup>3</sup> / <sub>16</sub> "  | 3 <sup>3</sup> / <sub>8</sub> " | 3/8"   | 1 1/4"                          | 7/32"                            | 3/4"                            |
| 3/8" O.D.  | 20-15LF6    | 20,000 | LF6        | 1 <sup>3</sup> / <sub>64</sub> " | 5 <sup>3</sup> / <sub>4</sub> "   | 2"                              | 1 <sup>11</sup> / <sub>16</sub> " | 1 <sup>3</sup> / <sub>16</sub> "  | 3 <sup>3</sup> / <sub>8</sub> " | 3/8"   | 1 1/4"                          | 7/32"                            | 3/4"                            |
| 9/16" O.D. | 20-15LF9    | 20,000 | LF9        | 5/16"                            | 8 <sup>7</sup> / <sub>8</sub> "   | 2 1/2"                          | 2 <sup>9</sup> / <sub>16</sub> "  | 1 <sup>3</sup> / <sub>4</sub> "   | 5 <sup>1</sup> / <sub>8</sub> " | 1 1/2" | 1 <sup>3</sup> / <sub>8</sub> " | 1 <sup>1</sup> / <sub>32</sub> " | 1"                              |
| 3/4" O.D.  | 20-15LF12   | 20,000 | LF12       | 7/16"                            | 9 <sup>3</sup> / <sub>4</sub> "   | 3"                              | 3 <sup>3</sup> / <sub>4</sub> "   | 2 <sup>1</sup> / <sub>4</sub> "   | 6 <sup>1</sup> / <sub>2</sub> " | 5/8"   | 1 <sup>3</sup> / <sub>4</sub> " | 7/16"                            | 1 <sup>3</sup> / <sub>8</sub> " |
| 3/4" O.D.  | 10-15LF12   | 10,000 | LF12       | 3 <sup>3</sup> / <sub>64</sub> " | 9 <sup>3</sup> / <sub>4</sub> "   | 3"                              | 3 <sup>3</sup> / <sub>4</sub> "   | 2 <sup>1</sup> / <sub>4</sub> "   | 6 <sup>1</sup> / <sub>2</sub> " | 5/8"   | 1 <sup>3</sup> / <sub>4</sub> " | 7/16"                            | 1 <sup>3</sup> / <sub>8</sub> " |
| 1" O.D.    | 20-15LF16   | 20,000 | LF16       | 9/16"                            | 12 <sup>3</sup> / <sub>16</sub> " | 4 <sup>1</sup> / <sub>8</sub> " | 4 <sup>1</sup> / <sub>8</sub> "   | 2 <sup>13</sup> / <sub>16</sub> " | 8 <sup>1</sup> / <sub>4</sub> " | 1 1/8" | 2 1/2"                          | 9/16"                            | 1 <sup>3</sup> / <sub>4</sub> " |
| 1" O.D.    | 10-15LF16   | 10,000 | LF16       | 1 <sup>1</sup> / <sub>16</sub> " | 12 <sup>3</sup> / <sub>16</sub> " | 4 <sup>1</sup> / <sub>8</sub> " | 4 <sup>1</sup> / <sub>8</sub> "   | 2 <sup>13</sup> / <sub>16</sub> " | 8 <sup>1</sup> / <sub>4</sub> " | 1 1/8" | 2 1/2"                          | 9/16"                            | 1 <sup>3</sup> / <sub>4</sub> " |

## Replaceable Seat Valves

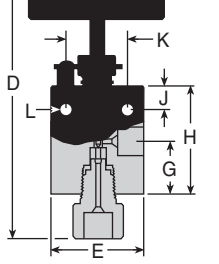

| Tubing     | Catalog No. | psi    | Connection | Orifice                          | D                                | E                               | F | G                                | H                                | J      | K                               | L                                | Thickness                       |
|------------|-------------|--------|------------|----------------------------------|----------------------------------|---------------------------------|---|----------------------------------|----------------------------------|--------|---------------------------------|----------------------------------|---------------------------------|
| 1/4" O.D.  | 20-12LF4-R  | 20,000 | LF4        | 1/8"                             | 5 <sup>5</sup> / <sub>8</sub> "  | 2"                              | — | 1 1/4"                           | 2 <sup>1</sup> / <sub>16</sub> " | 3/8"   | 1 1/4"                          | 7/32"                            | 3/4"                            |
| 3/8" O.D.  | 20-12LF6-R  | 20,000 | LF6        | 1 <sup>3</sup> / <sub>64</sub> " | 5 <sup>5</sup> / <sub>8</sub> "  | 2"                              | — | 1 1/4"                           | 2 <sup>1</sup> / <sub>16</sub> " | 3/8"   | 1 1/4"                          | 7/32"                            | 3/4"                            |
| 9/16" O.D. | 20-12LF9-R  | 20,000 | LF9        | 5/16"                            | 8"                               | 2 1/2"                          | — | 1 <sup>5</sup> / <sub>8</sub> "  | 3 <sup>3</sup> / <sub>8</sub> "  | 1 1/2" | 1 <sup>3</sup> / <sub>8</sub> " | 1 <sup>1</sup> / <sub>32</sub> " | 1"                              |
| 3/4" O.D.  | 20-12LF12-R | 20,000 | LF12       | 7/16"                            | 8 <sup>7</sup> / <sub>8</sub> "  | 3"                              | — | 2"                               | 4 1/4"                           | 5/8"   | 1 <sup>3</sup> / <sub>4</sub> " | 7/16"                            | 1 <sup>3</sup> / <sub>8</sub> " |
| 3/4" O.D.  | 10-12LF12-R | 10,000 | LF12       | 3 <sup>3</sup> / <sub>64</sub> " | 8 <sup>7</sup> / <sub>8</sub> "  | 3"                              | — | 2"                               | 4 1/4"                           | 5/8"   | 1 <sup>3</sup> / <sub>4</sub> " | 7/16"                            | 1 <sup>3</sup> / <sub>8</sub> " |
| 1" O.D.    | 20-12LF16-R | 20,000 | LF16       | 9/16"                            | 11 <sup>1</sup> / <sub>8</sub> " | 4 <sup>1</sup> / <sub>8</sub> " | — | 2 <sup>9</sup> / <sub>16</sub> " | 5 <sup>7</sup> / <sub>16</sub> " | 1 1/8" | 2 1/2"                          | 9/16"                            | 1 <sup>3</sup> / <sub>4</sub> " |
| 1" O.D.    | 10-12LF16-R | 10,000 | LF16       | 1 <sup>1</sup> / <sub>16</sub> " | 11 <sup>1</sup> / <sub>8</sub> " | 4 <sup>1</sup> / <sub>8</sub> " | — | 2 <sup>9</sup> / <sub>16</sub> " | 5 <sup>7</sup> / <sub>16</sub> " | 1 1/8" | 2 1/2"                          | 9/16"                            | 1 <sup>3</sup> / <sub>4</sub> " |

# Valve Options

## Extreme Temperature Valves

The Extreme Temperature Extension provides a means to move the packing area (stuffing box) away from the hot or cold zone of a valve. Fins are provided around the packing area to dissipate heat or cold with this option.

**Size range.** Extreme temperature extensions are available for all medium pressure valves.

**Materials and features.** Standard packing is Grafoil and Teflon. Nonrotating tip stems prevent galling at the seats and minimize torque requirements for positive shut off.

**When ordering,** simply add the suffix “-HT” or “-LT” to the standard valve catalog number (example: 20-11LF6-HT).

Temperature ratings of valves with this option, for low temperature (-LT) is -423°F (-252°C) and for high temperature (-HT) is 1200°F (649°C)

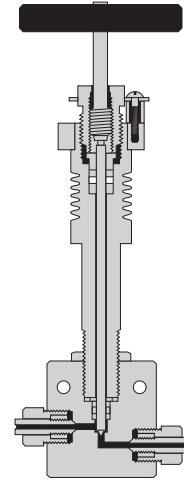

4

## Micro Control Metering Valves

The Micro Control Metering Valve assembly is available for 1/4", 3/8" valves in this section. This unique stem design operates on the principle of a right-hand threaded component operating in an opposite direction of motion to a left-hand threaded component.

As the pitch sizes of these threads are different from each other, a very fine and precise stem travel is made possible. This provides exceptional control that is not possible with ordinary fine pitched stem designs.

Each complete revolution of the stem provides 0.005" stem travel. The vernier indicator allows readings in increments of one-tenth of a revolution (0.0005" stem travel).

**The non-rotating lower section stem** is ground to a 9 degree included angle to insure maximum control. **While this valve may be turned to the fully off (closed) position, it is always preferable to provide a separate on-off valve in the system to protect the precise control of the metering valve.**

**When ordering,** simply specify the valve catalog number from the valve series and add the suffix “-V” (example: 20-11LF4-V)

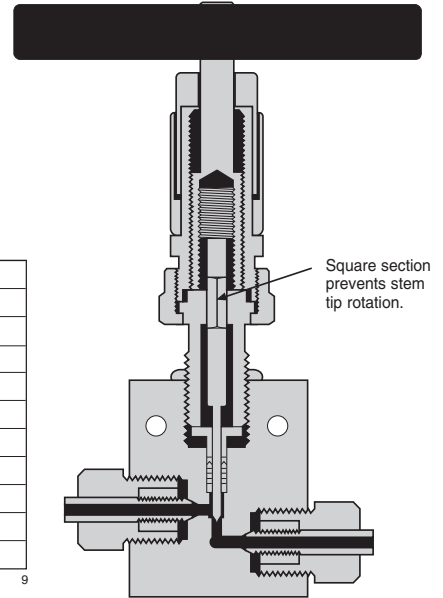
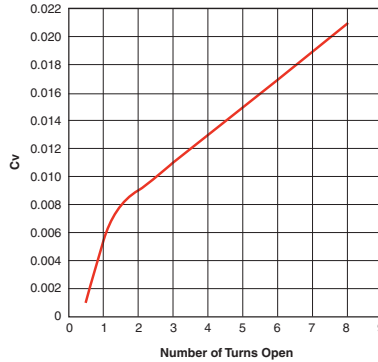

## Special Materials

A large number of the valves and fittings shown within this catalog section are frequently furnished in special materials to meet the requirements of specific applications. One of the most commonly requested “special” materials is Hastelloy C-276.

**Tubing collars and glands** for High Pressure coned-and-threaded connections are “non-wetted” parts which do not normally come into contact with the fluid or gas. Thus these items are supplied in 316 stainless steel unless otherwise specified.

**Packing material** in all special material valves is Teflon unless otherwise specified.

**Other materials.** In addition to Hastelloy C-276, valves and fittings can be furnished in Monel, Inconel and titanium. Consult factory for price and delivery.

## Packing Options

### Medium Pressure

| Material | Part Number |            |                         |                         |
|----------|-------------|------------|-------------------------|-------------------------|
|          | LF4/<br>LF6 | LF9        | LF12                    | LF16                    |
| Teflon*  | B-1392 Set  | 207341 Set | 208740 Set              | 208741 Set              |
| Grafoil  | B-1391 Set  | B-1386 Set | B-1455 Set <sup>1</sup> | B-1440 Set <sup>2</sup> |
| Polypak  | B-1388 (1)  | B-1387 (1) | B-1431 (1) <sup>1</sup> | B-1742 (1) <sup>2</sup> |

<sup>1</sup> LF12 Series: When Grafoil and Polypak are used, top washer 208937 and bottom washer 208939 must be installed



<sup>2</sup> LF16 Series: When Grafoil and Polypak are used, top washer 209308 and bottom washer 209309 must be installed

# Medium Pressure Valves

## Glands/Collars/Plugs/Elbows/Tees/Crosses

A complete range of elbows, tees, and crosses is available for all of the tubing connection sizes. Material is high tensile 316 stainless steel. Standard tubing glands and collars are provided unless otherwise specified.

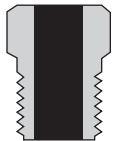
### Connection Components

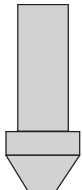
| Catalog No. | Tube Size | Gland   | Catalog No. | Tube Size | Collar  | Catalog No. | Tube Size | Plug  |
|-------------|-----------|---|-------------|-----------|---|-------------|-----------|---|
| 20-2LM4     | 1/4"      |  | 20-2L4      | 1/4"      |  | 20-7LM4     | 1/4"      |  |
| 20-2LM6     | 3/8"      |   | 20-2L6      | 3/8"      |   | 20-7LM6     | 3/8"      |   |
| 20-2LM9     | 9/16"     |   | 20-2L9      | 9/16"     |   | 20-7LM9     | 9/16"     |   |
| 20-2LM12    | 3/4"      |   | 20-2L12     | 3/4"      |   | 20-7LM12    | 3/4"      |   |
| 20-2LM16    | 1"        |   | 20-2L16     | 1"        |   | 20-7LM16    | 1"        |   |
| 15-2LM24    | 1 1/2"    |   | 15-2L24     | 1 1/2"    |   | 15-7LM24    | 1 1/2"    |   |

### Medium Pressure Elbows

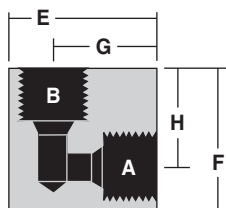

| Catalog No. | Pressure Rating psi | Connections      | A-B  | E       | F      | G       | H       | Thickness |
|-------------|---------------------|------------------|------|---------|--------|---------|---------|-----------|
| 20-22LF4    | 20,000              | 1/4" O.D. TUBE   | LF4  | 1 3/16" | 1"     | 7/8"    | 1 1/16" | 5/8"      |
| 20-22LF6    | 20,000              | 3/8" O.D. TUBE   | LF6  | 1 3/8"  | 1 3/8" | 1"      | 1"      | 3/4"      |
| 20-22LF9    | 20,000              | 9/16" O.D. TUBE  | LF9  | 1 3/4"  | 1 3/4" | 1 1/4"  | 1 1/4"  | 1"        |
| 20-22LF12   | 20,000              | 3/4" O.D. TUBE   | LF12 | 2 1/4"  | 2 1/4" | 1 1/2"  | 1 1/2"  | 1 3/8"    |
| 20-22LF16   | 20,000              | 1" O.D. TUBE     | LF16 | 3"      | 3"     | 2 1/16" | 2 1/16" | 1 3/4"    |
| 15-22LF24   | 15,000              | 1 1/2" O.D. TUBE | LF24 | 5 3/4"  | 4"     | 2 7/8"  | 2 7/8"  | 2 1/4"    |

### Medium Pressure Tees

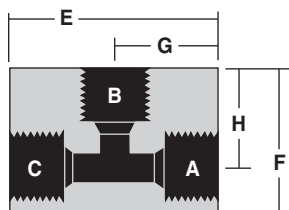

| Catalog No. | Pressure Rating psi | Connections      | A-B-C | E      | F      | G       | H       | Thickness |
|-------------|---------------------|------------------|-------|--------|--------|---------|---------|-----------|
| 20-23LF4    | 20,000              | 1/4" O.D. TUBE   | LF4   | 1 3/4" | 1"     | 7/8"    | 1 1/16" | 5/8"      |
| 20-23LF6    | 20,000              | 3/8" O.D. TUBE   | LF6   | 2"     | 1 3/8" | 1"      | 1"      | 3/4"      |
| 20-23LF9    | 20,000              | 9/16" O.D. TUBE  | LF9   | 2 1/2" | 1 3/4" | 1 1/4"  | 1 1/4"  | 1"        |
| 20-23LF12   | 20,000              | 3/4" O.D. TUBE   | LF12  | 3"     | 2 1/4" | 1 1/2"  | 1 1/2"  | 1 3/8"    |
| 20-23LF16   | 20,000              | 1" O.D. TUBE     | LF16  | 4 1/8" | 3"     | 2 1/16" | 2 1/16" | 1 3/4"    |
| 15-23LF24   | 15,000              | 1 1/2" O.D. TUBE | LF24  | 5 3/4" | 4"     | 2 7/8"  | 2 7/8"  | 2 1/4"    |

### Medium Pressure Crosses

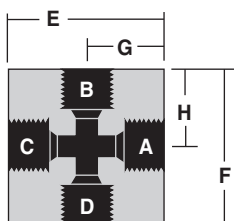

| Catalog No. | Pressure Rating psi | Connections      | A-B-C-D | E      | F      | G       | H       | Thickness |
|-------------|---------------------|------------------|---------|--------|--------|---------|---------|-----------|
| 20-24LF4    | 20,000              | 1/4" O.D. TUBE   | LF4     | 1 3/4" | 1 3/8" | 7/8"    | 1 1/16" | 5/8"      |
| 20-24LF6    | 20,000              | 3/8" O.D. TUBE   | LF6     | 2"     | 2"     | 1"      | 1"      | 3/4"      |
| 20-24LF9    | 20,000              | 9/16" O.D. TUBE  | LF9     | 2 1/2" | 2 1/2" | 1 1/4"  | 1 1/4"  | 1"        |
| 20-24LF12   | 20,000              | 3/4" O.D. TUBE   | LF12    | 3"     | 3"     | 1 1/2"  | 1 1/2"  | 1 3/8"    |
| 20-24LF16   | 20,000              | 1" O.D. TUBE     | LF16    | 4 1/8" | 4 1/8" | 2 1/16" | 2 1/16" | 1 3/4"    |
| 15-24LF24   | 15,000              | 1 1/2" O.D. TUBE | LF24    | 5 3/4" | 5 3/4" | 2 7/8"  | 2 7/8"  | 2 1/4"    |

## Union Couplings (Slip Type)

Union (slip type) couplings are ideal for use in confined space installations. This design allows the entire coupling to be disconnected and slipped back over the tubing to facilitate assembly and disassembly. In installations where tubing is easily assembled, it is preferable (and less expensive) to use standard straight couplings (see section 8.0). Standard material is high tensile 316 stainless steel. Standard tubing collars and glands are provided unless otherwise specified.

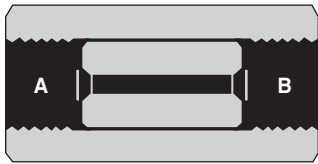

| Catalog No. | Tubing      | psi    | A    | B    | Orifice | Length  | Hex    |
|-------------|-------------|--------|------|------|---------|---------|--------|
| 20-21LF4-U  | 1/4" O.D.   | 20,000 | LF4  | LF4  | 1/8"    | 1 9/16" | 5/8"   |
| 20-21LF6-U  | 3/8" O.D.   | 20,000 | LF6  | LF6  | 7/32"   | 1 3/4"  | 3/4"   |
| 20-21LF9-U  | 9/16" O.D.  | 20,000 | LF9  | LF9  | 23/64"  | 2 1/2"  | 1"     |
| 20-21LF12-U | 3/4" O.D.   | 20,000 | LF12 | LF12 | 33/64"  | 2 1/2"  | 1 3/8" |
| 20-21LF16-U | 1" O.D.     | 20,000 | LF16 | LF16 | 11/16"  | 3 1/2"  | 1 3/4" |
| 15-21LF24-U | 1 1/2" O.D. | 15,000 | LF24 | LF24 | 15/16"  | 5"      | 2 1/4" |

4

## Bulkhead Couplings

Bulkhead couplings are designed specifically for passing a tubing connection through a panel or steel barricade. These couplings include a locknut as shown. Material is high tensile 316 stainless steel. Standard tubing collars and glands are included unless otherwise specified.

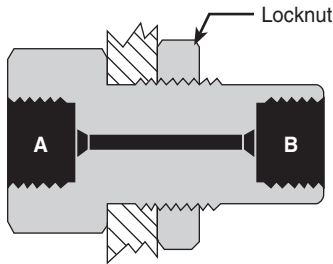

| Catalog No. | Tubing      | psi    | Connections | Orifice | Length | Hex    | Hole Diameter | Max. Panel Thickness |
|-------------|-------------|--------|-------------|---------|--------|--------|---------------|----------------------|
| 20-21LF4-B  | 1/4" O.D.   | 20,000 | LF4         | 1/8"    | 1 7/8" | 1"     | 13/16"        | 13/32"               |
| 20-21LF6-B  | 3/8" O.D.   | 20,000 | LF6         | 7/32"   | 2"     | 1"     | 15/16"        | 7/16"                |
| 20-21LF9-B  | 9/16" O.D.  | 20,000 | LF9         | 23/64"  | 2 3/8" | 1 3/8" | 1 1/8"        | 17/32"               |
| 20-21LF12-B | 3/4" O.D.   | 20,000 | LF12        | 33/64"  | 2 5/8" | 1 7/8" | 1 11/16"      | 3/8"                 |
| 20-21LF16-B | 1" O.D.     | 20,000 | LF16        | 11/16"  | 3 1/2" | 2 1/8" | 1 15/16"      | 3/8"                 |
| 15-21LF24-B | 1 1/2" O.D. | 15,000 | LF24        | 15/16"  | 5"     | 2 1/2" | 2 7/16"       | 1"                   |

## Caps

Tubing end caps are offered for use in sealing off tubing ends either for temporary use or permanent use, such as on small volume reservoirs. Standard material is high tensile 316 stainless steel. Standard tubing collars and glands are provided unless otherwise specified.

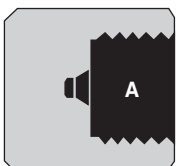

| Catalog No. | Tubing      | psi    | A    | Length | Hex    |
|-------------|-------------|--------|------|--------|--------|
| 20-21LF4-C  | 1/4" O.D.   | 20,000 | LF4  | 7/8"   | 5/8"   |
| 20-21LF6-C  | 3/8" O.D.   | 20,000 | LF6  | 1 3/8" | 3/4"   |
| 20-21LF9-C  | 9/16" O.D.  | 20,000 | LF9  | 1 1/2" | 1"     |
| 20-21LF12-C | 3/4" O.D.   | 20,000 | LF12 | 2 1/2" | 1 3/8" |
| 20-21LF16-C | 1" O.D.     | 20,000 | LF16 | 3"     | 1 3/4" |
| 15-21LF24-C | 1 1/2" O.D. | 15,000 | LF24 | 3 1/2" | 2 1/4" |

# Medium Pressure Valves

## Line Filters

The line filters as shown utilize sintered stainless steel filter discs 4 pc./set. Porosities are available as per the chart to the right. If not otherwise specified, 100 micron filter discs are supplied. (One micron = 0.001 millimeters). Material of body, caps and cover is high tensile 316 stainless steel. Standard tubing glands and collars are provided unless otherwise specified.

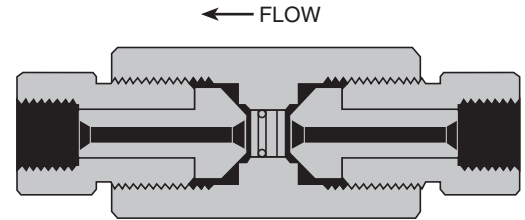

| Catalog No. | Tubing     | psi    | Connections | Orifice | Length | Thickness | Micron Size Filter Available |   |   |    |    |     |
|-------------|------------|--------|-------------|---------|--------|-----------|------------------------------|---|---|----|----|-----|
|             |            |        |             |         |        |           | 0.5                          | 2 | 5 | 10 | 40 | 100 |
| 20-51LF4    | 1/4" O.D.  | 20,000 | LF4         | 1/8"    | 5 1/4" | 1 3/8"    | ●                            | ● | ● | ●  | ●  | ●   |
| 20-51LF6    | 3/8" O.D.  | 20,000 | LF6         | 7/32"   | 5 1/4" | 1 3/8"    | ●                            | ● | ● | ●  | ●  | ●   |
| 20-51LF9    | 9/16" O.D. | 20,000 | LF9         | 23/64"  | 5 1/4" | 1 3/8"    | ●                            | ● | ● | ●  | ●  | ●   |

4

## Ball Check Valves

Ball type check valves insure flow in one direction only. Material for body, caps and cover is high tensile 316 stainless steel. Standard tubing glands and collars are provided unless otherwise specified.

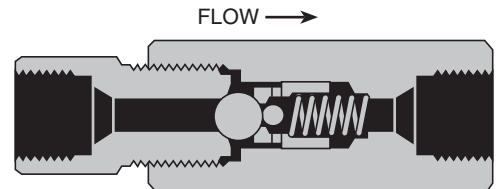

| Catalog No. | Tubing     | psi    | Connections | Orifice | Length | Thickness |
|-------------|------------|--------|-------------|---------|--------|-----------|
| 20-41LF4    | 1/4" O.D.  | 20,000 | LF4         | 1/8"    | 3 3/4" | 1"        |
| 20-41LF6    | 3/8" O.D.  | 20,000 | LF6         | 7/32"   | 3 3/4" | 1"        |
| 20-41LF9    | 9/16" O.D. | 20,000 | LF9         | 23/64"  | 4 1/2" | 1 3/8"    |
| 20-41LF12   | 3/4" O.D.  | 20,000 | LF12        | 7/16"   | 5 1/8" | 1 3/4"    |
| 20-41LF16   | 1" O.D.    | 20,000 | LF16        | 9/16"   | 6 1/2" | 2 1/2"    |

Note: 20-41LF16 material 17-4PH

## Soft Seat Check Valves

Soft seat check valves insure flow in one direction only and can be mounted in any position. These are highly reliable for both gas and liquid service. Standard material for the sealing surface (soft seat) is Buna-N (nitrile) on 1/4", 3/8" and 9/16" models, and Teflon on 3/4" and 1" models, with other materials (including each of these, as well as Viton) available upon request. Temperature is limited by the choice of O-ring material. Material of all other parts is high tensile 316 stainless steel. Standard glands and collars are provided unless otherwise specified.

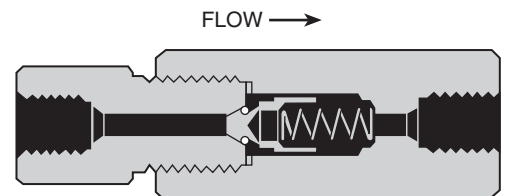

| Catalog No. | Tubing     | psi    | Connections | Orifice | Length | Thickness |
|-------------|------------|--------|-------------|---------|--------|-----------|
| 20-41LF4-T  | 1/4" O.D.  | 20,000 | LF4         | 1/8"    | 3 3/4" | 1"        |
| 20-41LF6-T  | 3/8" O.D.  | 20,000 | LF6         | 7/32"   | 3 3/4" | 1"        |
| 20-41LF9-T  | 9/16" O.D. | 20,000 | LF9         | 23/64"  | 4 1/2" | 1 3/8"    |
| 20-41LF12-T | 3/4" O.D.  | 20,000 | LF12        | 7/16"   | 5 1/8" | 1 3/4"    |
| 20-41LF16-T | 1" O.D.    | 20,000 | LF16        | 9/16"   | 6 1/2" | 2 1/2"    |

Note: 20-41LF16 material 17-4PH

## Safety Heads

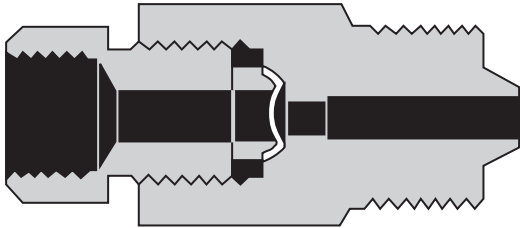

CE marked safety heads are now available, add -CE to end of standard part number. Consult factory for pricing.

The male inlet design can be inserted directly into the tubing connections of valves and various fittings such as tees and crosses, or located in pressure vessels.

Outlet connections are  $\frac{3}{8}$ " pipe (NPT). This outlet may be connected to a suitable discharge line to vent pressure to a safe location in the event of bursting of the rupture disc. Torque required for sealing rupture discs will range from 40 to 90 foot pounds, depending upon pressure and media being used.

Material of body and hold down nut is high tensile 316 stainless steel. Standard tubing glands and collars are provided unless otherwise specified.

**Note:** Rupture discs are **not** included and must be ordered as a separate item.

4

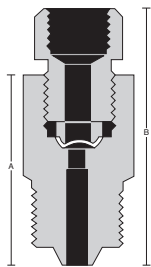

### Male Inlet Safety Heads

| Catalog No. | Pressure Rating psi | Inlet Connection                 | A                | B                | Hex Size         |
|-------------|---------------------|----------------------------------|------------------|------------------|------------------|
| 20-61LM4    | 20,000              | $\frac{1}{4}$ " MEDIUM PRESSURE  | 2"               | 3"               | 1"               |
| 20-61LM6    | 20,000              | $\frac{3}{8}$ " MEDIUM PRESSURE  | $2\frac{1}{8}$ " | $3\frac{1}{8}$ " | 1"               |
| 20-61LM9    | 20,000              | $\frac{9}{16}$ " MEDIUM PRESSURE | $2\frac{1}{4}$ " | $3\frac{1}{4}$ " | 1"               |
| 20-61LM12   | 20,000              | $\frac{3}{4}$ " MEDIUM PRESSURE  | $2\frac{1}{2}$ " | $3\frac{1}{2}$ " | $1\frac{1}{4}$ " |
| 20-61LM16   | 20,000              | 1" MEDIUM PRESSURE               | $3\frac{3}{8}$ " | $4\frac{3}{8}$ " | $1\frac{1}{8}$ " |

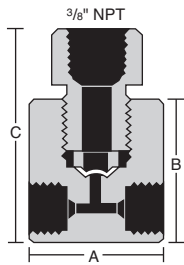

### Tee Type Safety Heads

| Catalog No. | Pressure Rating psi | Inlet Connection                 | A                | B                | Thickness        |
|-------------|---------------------|----------------------------------|------------------|------------------|------------------|
| 20-63LF4    | 20,000              | $\frac{1}{4}$ " MEDIUM PRESSURE  | $1\frac{1}{2}$ " | $1\frac{5}{8}$ " | $2\frac{5}{8}$ " |
| 20-63LF6    | 20,000              | $\frac{3}{8}$ " MEDIUM PRESSURE  | 2"               | $1\frac{3}{4}$ " | $2\frac{3}{4}$ " |
| 20-63LF9    | 20,000              | $\frac{9}{16}$ " MEDIUM PRESSURE | $2\frac{1}{2}$ " | 2"               | 3"               |

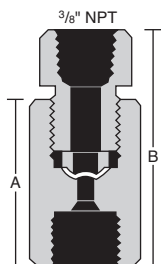

### Female Inlet (Straight) Safety Heads

| Catalog No. | Pressure Rating psi | Inlet Connection                | A                | B                | Hex Size |
|-------------|---------------------|---------------------------------|------------------|------------------|----------|
| 20-61LF4    | 20,000              | $\frac{1}{4}$ " MEDIUM PRESSURE | $1\frac{7}{8}$ " | $2\frac{7}{8}$ " | 1"       |
| 20-61LF6    | 20,000              | $\frac{3}{8}$ " MEDIUM PRESSURE | 2"               | 3"               | 1"       |
| 20-61LF9    | 20,000              | $\frac{1}{4}$ " MEDIUM PRESSURE | $2\frac{1}{4}$ " | $3\frac{1}{4}$ " | 1"       |

# Medium Pressure Valves

## Rupture Discs

### 1/4" Angled Seat

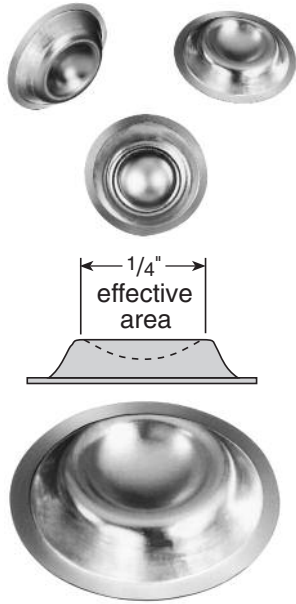

**SPECIAL DISCS** are available on special order for pressure ranges not shown below and in numerous materials and coatings. Consult factory for price and delivery.

Standard rupture discs are available from stock in burst pressures as listed in the chart below. All pressures through 20,000 psi are shaded. These discs are 316 stainless steel (except for 1,000 psi which are inconel) and may be used with any of the safety heads shown. Note that these rupture discs are supplied with a range of plus 6% and minus 3% of specified burst pressure. Samples of each batch are then tested and typically the actual average burst pressure is stamped on an accompanying metal tag. There is a +/- 5% burst tolerance applied after the burst pressure has been established. Factors influencing rupture disc life include corrosion, metal fatigue, and cyclic effects. Periodic replacement is recommended to prevent premature failure.

### Standard Burst Pressures (in psi at 72°F)

|       |       |       |       |        |        |        |        |        |        |
|-------|-------|-------|-------|--------|--------|--------|--------|--------|--------|
| 1,000 | 3,000 | 5,000 | 7,000 | 9,000  | 11,000 | 17,500 | 25,000 | 37,500 | 55,000 |
| 1,500 | 3,500 | 5,500 | 7,500 | 9,500  | 11,500 | 18,000 | 27,000 | 40,000 | 60,000 |
| 2,000 | 4,000 | 6,000 | 8,000 | 10,000 | 12,500 | 20,000 | 30,000 | 45,000 | 65,000 |
| 2,500 | 4,500 | 6,500 | 8,500 | 10,500 | 15,000 | 22,500 | 35,000 | 50,000 |        |

## Anti-Vibration Gland Assemblies

Tubing systems that are subject to extreme vibration or shock, such as mobile pressure systems or long tubing runs culminating at a compressor, will benefit from the use of High Pressure Equipment Company's Anti-Vibration Gland Assemblies. These assemblies utilize the same reliable connection geometries as the standard HiP fittings, with the added benefit of essentially unlimited vibrational fatigue life.

A coned and threaded tube, when subjected to unusual or excessive vibration, may fail prematurely and break at the last thread. The Anti-Vibration Gland Assembly acts to move the fulcrum of vibration away from the threaded portion of the tube and onto the strong, solid wall of the tubing. A wedge-like collet firmly holds the assembly in place, virtually eliminating premature tubing failure while reliably maintaining a leak-free connection between the tube and the connection seat.

4

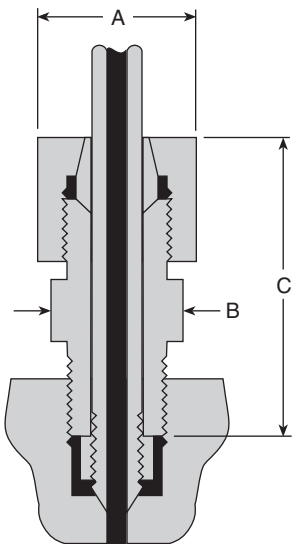

### Medium Pressure Anti-Vibration Gland Assemblies

| Catalog No. | Pressure Rating psi | Connections           | A      | B      | C       |
|-------------|---------------------|-----------------------|--------|--------|---------|
| 20-3LM4     | 20,000              | 1/4" MEDIUM PRESSURE  | 5/8"   | 1/2"   | 1 7/16" |
| 20-3LM6     | 20,000              | 3/8" MEDIUM PRESSURE  | 3/4"   | 5/8"   | 1 5/8"  |
| 20-3LM9     | 20,000              | 9/16" MEDIUM PRESSURE | 1"     | 7/8"   | 1 7/8"  |
| 20-3LM12    | 20,000              | 3/4" MEDIUM PRESSURE  | 1 1/4" | 1 1/8" | 2 1/8"  |
| 20-3LM16    | 20,000              | 1" MEDIUM PRESSURE    | 1 1/2" | 1 3/8" | 2 1/2"  |

### Anti-Vibration Components

| Tubing Size | Slotted Collet | Collet Gland | Collet Body | Collar  |
|-------------|----------------|--------------|-------------|---------|
| 1/4"        | 2-8769         | 2-8770       | 2-8768      | 20-2L4  |
| 3/8"        | 2-8772         | 2-8773       | 2-8771      | 20-2L6  |
| 9/16"       | 2-8775         | 2-8776       | 2-8774      | 20-2L9  |
| 3/4"        | 2-8778         | 2-8779       | 2-8777      | 20-2L12 |
| 1"          | 2-8781         | 2-8782       | 2-8780      | 20-2L16 |

# Medium Pressure Valves

## Medium Pressure Tubing

Tubing is cold drawn, seamless, and is supplied in the  $\frac{1}{8}$  hard condition (not annealed). Tensile strength is approximately 40 percent higher than that of annealed tubing. All tubing is manufactured in strict accordance with High Pressure Equipment Company specifications to insure tolerances and bore quality. Tubing is stocked in lengths of 20 to 24 feet but may be ordered in shorter lengths with **no additional cutting charge**.

|               | Tubing Size               | Working Pressure psi | Wall Thickness | Type of Connection Used       | Material | Catalog Order Number |
|---------------|---------------------------|----------------------|----------------|-------------------------------|----------|----------------------|
| <b>1/4"</b>   | 1/4" O.D. x 0.109" I.D.   | 20,000               | 0.070"         | 1/4" MEDIUM PRESSURE (LF4)    | 316 SS   | 20-9M4-316           |
| <b>3/8"</b>   | 3/8" O.D. x 0.203" I.D.   | 20,000               | 0.086"         | 3/8" MEDIUM PRESSURE (LF6)    | 316 SS   | 20-9M6-316           |
| <b>9/16"</b>  | 9/16" O.D. x 0.359" I.D.  | 15,000               | 0.100"         | 9/16" MEDIUM PRESSURE (LF9)   | 316 SS   | 10-9M9-316           |
|               | 9/16" O.D. x 0.312" I.D.  | 20,000               | 0.124"         |                               | 304 SS   | 20-9M9-304           |
|               |                           |                      |                |                               | 316 SS   | 20-9M9-316           |
| <b>3/4"</b>   | 3/4" O.D. x 0.516" I.D.   | 15,000               | 0.117"         | 3/4" MEDIUM PRESSURE (LF12)   | 316 SS   | 10-9M12-316          |
|               | 3/4" O.D. x 0.438" I.D.   | 20,000               | 0.156"         |                               |          | 20-9M12-316          |
| <b>1"</b>     | 1" O.D. x 0.688" I.D.     | 15,000               | 0.156"         | 1" MEDIUM PRESSURE (LF16)     | 316 SS   | 10-9M16-316          |
|               | 1" O.D. x 0.562" I.D.     | 20,000               | 0.219"         |                               |          | 20-9M16-316          |
| <b>1 1/2"</b> | 1 1/2" O.D. x 0.937" I.D. | 15,000               | 0.281"         | 1 1/2" MEDIUM PRESSURE (LF24) | 316 SS   | 15-9M24-316          |

## Nipples

Nipples are stocked in 316 stainless steel. Nipples in lengths other than those shown are supplied upon request. Nipples are not furnished with collars and glands, unless specified at time of order.



### Coned and Threaded Nipples

| Length<br>↓ | Tubing Size (O.D. x I.D.) |                            |                            |                            |                           |                          |                         |                              |
|-------------|---------------------------|----------------------------|----------------------------|----------------------------|---------------------------|--------------------------|-------------------------|------------------------------|
|             | 1/4" O.D. x<br>7/64" I.D. | 3/8" O.D. x<br>13/64" I.D. | 9/16" O.D. x<br>5/16" I.D. | 3/4" O.D. x<br>33/64" I.D. | 3/4" O.D. x<br>7/16" I.D. | 1" O.D. x<br>11/16" I.D. | 1" O.D. x<br>9/16" I.D. | 1 1/2" O.D. x<br>15/16" I.D. |
| psi →       | 20,000 psi                | 20,000 psi                 | 20,000 psi                 | 10,000 psi                 | 20,000 psi                | 10,000 psi               | 20,000 psi              | 15,000 psi                   |
| 2 3/4"      | 20-LM4-2.75               |                            |                            |                            |                           |                          |                         |                              |
| 3"          |                           | 20-LM6-3                   |                            |                            |                           |                          |                         |                              |
| 4"          |                           |                            | 20-LM9-4                   | 10-LM12-4                  |                           |                          |                         |                              |
| 6"          | 20-LM4-6                  | 20-LM6-6                   | 20-LM9-6                   | 10-LM12-6                  | 20-LM12-6                 | 10-LM16-6                | 20-LM16-6               | 15-LM24-6                    |
| 8"          | 20-LM4-8                  | 20-LM6-8                   | 20-LM9-8                   | 10-LM12-8                  | 20-LM12-8                 | 10-LM16-8                | 20-LM16-8               | 15-LM24-8                    |
| 10"         | 20-LM4-10                 | 20-LM6-10                  | 20-LM9-10                  | 10-LM12-10                 | 20-LM12-10                | 10-LM16-10               | 20-LM16-10              | 15-LM24-10                   |
| 12"         | 20-LM4-12                 | 20-LM6-12                  | 20-LM9-12                  | 10-LM12-12                 | 20-LM12-12                | 10-LM16-12               | 20-LM16-12              | 15-LM24-12                   |

## Medium Pressure Connections

The Medium Pressure tubing connection is available for 1/4", 3/8", 9/16", 3/4", and 1" O.D. tubing. The tubing may be prepared with the use of tooling (see tooling section 9.0) or prepared at the factory to specified lengths. Additionally, standard length coned and threaded nipples are available from stock (see page 38).

This connection has become an industry standard for use at elevated pressures and temperatures in both liquid and gas applications. It may be disassembled and retightened indefinitely. The threads of the gland are right-hand while the threads of the collar and tubing are left-hand to prevent rotation of the collar during assembly.

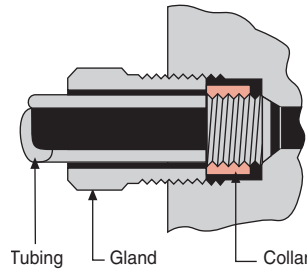

**Materials.** All of the components required for make-up of a Medium Pressure connection (glands, collars and plugs) are produced in Type 316 stainless steel.

**Glands and collars.** All valves and fittings are provided (except nipples) unless otherwise requested. (See chart on the right for size details and catalog numbers).

4

| 20,000 psi   |   |  |  |   |   |
|--|---|--|--|---|---|
| LF4<br>1/4" O.D. Tubing                              | LF6<br>3/8" O.D. Tubing                               | LF9<br>9/16" O.D. Tubing                               | LF12<br>3/4" O.D. Tubing                                     | LF16<br>1" O.D. Tubing  | LF24<br>1 1/2" O.D. Tubing  |
| <b>Female Opening Detail</b>                         |   |  |  |   |   |
| <br>7/16" - 20<br>60°<br>1/8" - 3/16"<br>1/2"<br>LF4 | <br>9/16" - 18<br>60°<br>7/32" - 5/16"<br>5/8"<br>LF6 | <br>13/16" - 16<br>60°<br>23/64" - 1/2"<br>3/4"<br>LF9 | <br>3/4" - 14 NPSM<br>60°<br>5/8" - 33/64"<br>15/16"<br>LF12 | <br>1 - 3/8" - 12 TH'D<br>60°<br>7/8" - 11/16"<br>1 - 5/16"<br>LF16 | <br>1 - 7/8" - 12" Thread<br>60°<br>1 - 3/8" - 15/16"<br>1 - 5/8"<br>LF24 |
| <b>Gland</b>   |   |  |  |   |   |
| <br>1/2" - 11/16"<br>7/16" - 20<br>20-2LM4           | <br>5/8" - 13/16"<br>9/16" - 18<br>20-2LM6            | <br>7/8" - 1-1/16"<br>13/16" - 16<br>20-2LM9           | <br>1 - 1/8" HEX - 1-1/8"<br>3/4" - 14 NPSM<br>20-2LM12      | <br>1 - 3/8" HEX - 1-1/2"<br>1 - 3/8" - 12<br>20-2LM16              | <br>1 - 7/8" Hex - 2"<br>1 - 7/8" - 12" Thread<br>15-2LM24                |
| <b>Collar</b>  |   |  |  |   |   |
| <br>1/4" - 28 L.H. - 7/32"<br>3/8"<br>20-2L4         | <br>3/8" - 24 L.H. - 1/4"<br>15/32"<br>20-2L6         | <br>9/16" - 18 L.H. - 5/16"<br>23/32"<br>20-2L9        | <br>3/4" - 16 L.H. - 3/8"<br>15/16"<br>20-2L12               | <br>1 - 1/4" - 1" - 14 L.H. - 1/2"<br>20-2L16                       | <br>1 - 3/4" - 1 - 1/2" - 12 L.H. - 1/2"<br>15-2L24                       |
| <b>Plug</b>  |   |  |  |   |   |
| <br>1/4" - 1" - 3/8"<br>20-7LM4                      | <br>3/8" - 1-1/4" - 15/32"<br>20-7LM6                 | <br>9/16" - 1-9/16" - 23/32"<br>20-7LM9                | <br>1-1/8" - 1-3/4" - 9/16"<br>20-7LM12                      | <br>1-9/16" - 2-3/8" - 23/32"<br>20-7LM16                           | <br>2" - 2-15/16" - 1-1/16"<br>15-7LM24                                   |
| <b>Tube End Prep</b>                                 |   |  |  |   |   |
| <br>59° - 11/32"<br>9/64" - 1/4" - 28 L.H.<br>LM4    | <br>59° - 7/16"<br>1/4" - 3/8" - 24 L.H.<br>LM6       | <br>59° - 1/2"<br>13/32" - 9/16" - 18 L.H.<br>LM9      | <br>59° - 5/8"<br>9/16" - 3/4" - 16 L.H.<br>LM12             | <br>59° - 25/32"<br>9/16" - 1" - 14 L.H.<br>LM16                    | <br>59° - 15/16"<br>15/16" - 1-1/16" - 1-1/2" - 12 L.H.<br>LM24           |