

High Pressure Hand Pumps

S-525-()

This single-acting, piston type hand pump is ideal for hydrostatic testing and other industrial applications that require low volumes at high pressures.

The pump's stainless steel liquid body assembly (wetted section) is identical to and interchangeable with the liquid body assembly in the S-216-J-() standard pump, so the hand pump will service water, oil and most corrosive chemicals.

Directional control of the liquid through the pump is maintained through the inlet and outlet soft seat, zero leakage, check valves.

The pump is seven inches high from its base to the top of the pumping mechanism. The handle extends twenty-four inches and is furnished with a rubber grip.

The pump has two threaded mounting holes provided on the underside of the liquid body. The -35, -60 and -100 pumps may be installed below or no more than two feet above the liquid source. The -150, -200 and -300 pumps must be installed with the pump inlet below the liquid source.



Nominal Dimensions and Clearances

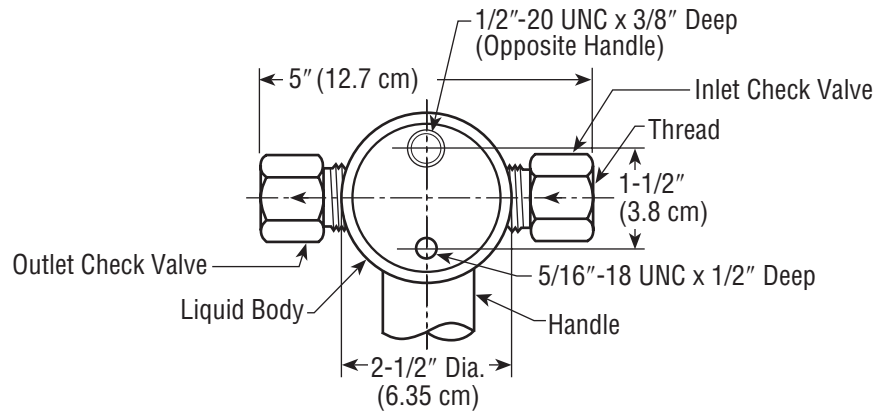

Mounting Dimension – Bottom View

Hand Pump Model Number	Pump Output with 75 lbs. Handle Load	Liquid Inlet	Liquid Outlet	Shipping Weight	Displacement cu. in.
S-525-35	2220 psi	3/8 NPT	3/8 NPT	12 lbs.	.708
S-525-60	3020 psi	3/8 NPT	3/8 NPT	12 lbs.	.527
S-525-100	4350 psi	3/8 NPT	3/8 NPT	12 lbs.	.366
S-525-150	6800 psi	1/4 NPT	9/16-18 NBS	12 lbs.	.205
S-525-200	12000 psi	1/4 NPT	9/16-18 NBS	12 lbs.	.132
S-525-300	17400 psi	1/4 NPT	9/16-18 NBS	12 lbs.	.092