

Sprague

Air Driven Hydraulic Pumps

HIP offers a full line of Sprague hydraulic pumps for various liquid output pressures up to 36,500 psi (2516 bar). Sprague pumps service water, oil and most corrosive chemicals, and are rugged, service-proven and virtually maintenance-free.

2

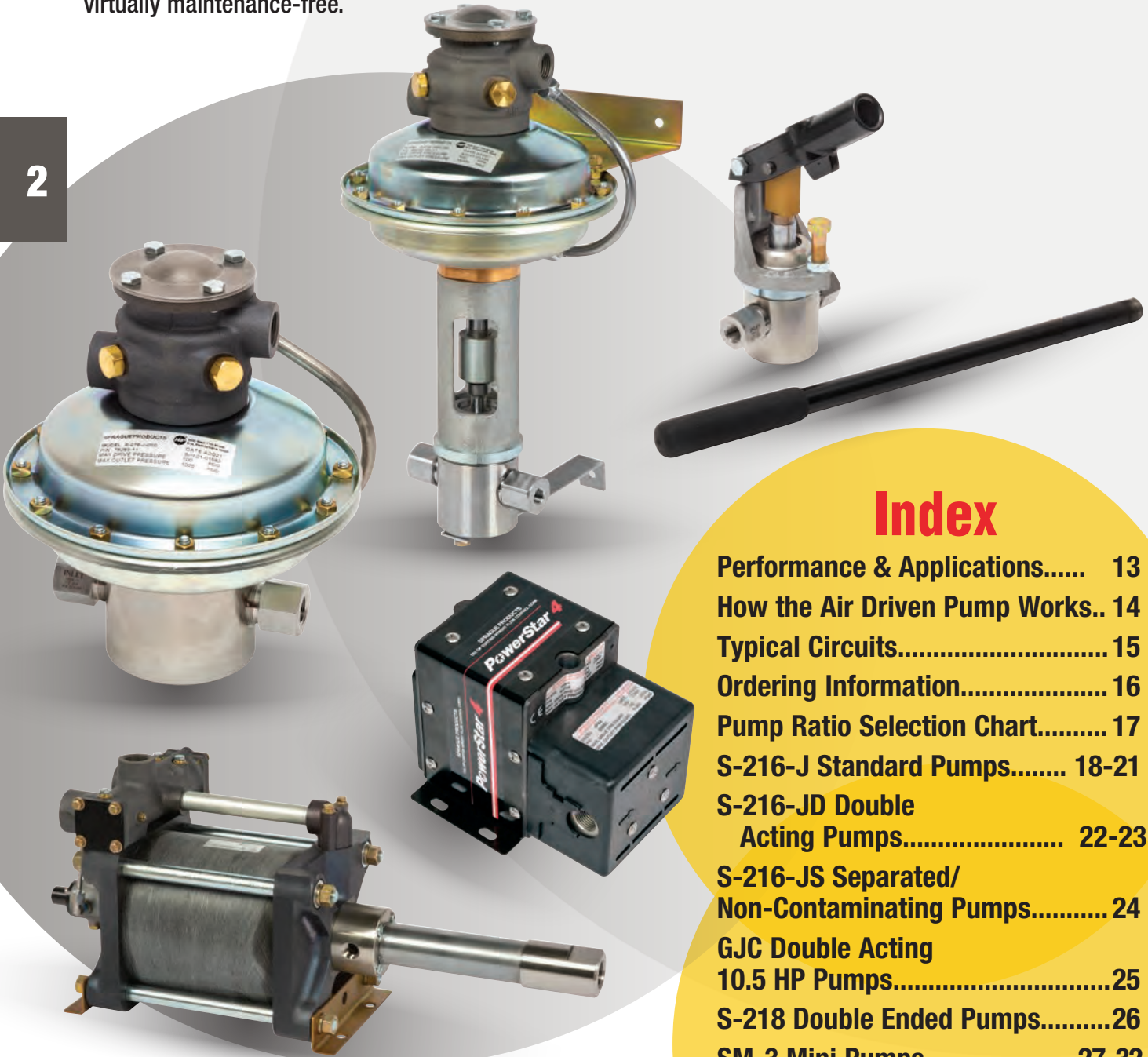

Index

Performance & Applications.....	13
How the Air Driven Pump Works..	14
Typical Circuits.....	15
Ordering Information.....	16
Pump Ratio Selection Chart.....	17
S-216-J Standard Pumps.....	18-21
S-216-JD Double Acting Pumps.....	22-23
S-216-JS Separated/ Non-Contaminating Pumps.....	24
GJC Double Acting 10.5 HP Pumps.....	25
S-218 Double Ended Pumps.....	26
SM-3 Mini Pumps.....	27-32
PowerStar 4 Pumps.....	33-38
JB Hand Pumps.....	39
JR Portable Pump Reservoir....	40-41

Performance & Applications

for Air Driven Hydraulic Pumps

The Sprague air driven positive-displacement type pump converts air inlet pressure to hydraulic output pressure. The pump uses low pressure air to act on a large area piston to produce high hydraulic pressure with a small area piston.

In operation, the pump reciprocates rapidly until the system liquid pressure nears the desired level, then slows to a stop when the liquid pressure equals or balances the air pressure. This liquid-air pressure balance is maintained indefinitely in a holding condition with minimal energy consumption or parts movement and with no increase in fluid temperature.

In contrast, a motor driven pump in a holding condition must continue to operate to maintain a pressure level. Excess liquid must be bypassed or recirculated back to the reservoir, resulting in energy loss, heat build-up, and the need for bypass components and a larger reservoir.

The Sprague pump is efficient in operation and simple in design. Compared to other types of hydraulic pumps, it provides cost effective and energy saving benefits for many industrial and research applications.

Hydrostatic Testing Applications

The Sprague air driven pump offers economical advantages for the pressure testing of hoses, pipes, valves, fittings and other hydraulic vessels and products. The time saving and performance advantages offered by these pumps allow routine production testing to be converted from tedious hand-pump methods to automatic and precision testing methods.

Production Machinery Applications

The Sprague air driven pump delivers high pressure liquids required by production machinery for holding, clamping, forming, shearing, punching, etc.

An application example: a hydraulic press where long holding cycles are necessary or where the work stroke is short and a high force is required. High and low volume pumps can be combined to produce a combination of high speed and high force at low cost.

No Need For Central Power Source

Because Sprague air driven pumps are relatively small, they can be installed directly on individual machines or test equipment in separate locations as direct power sources. Pumps so mounted eliminate need for a central power system, long plumbing runs and excess hydraulic power capacity.

Safe Operation

Unlike motor driven pumps, Sprague air driven pumps are non-arcing and non-sparking, and can be used safely in hazardous or confined areas.

Simpler Maintenance

When compared to other air driven pumps, Sprague pumps do the same job, but with fewer parts and seals for simpler maintenance.

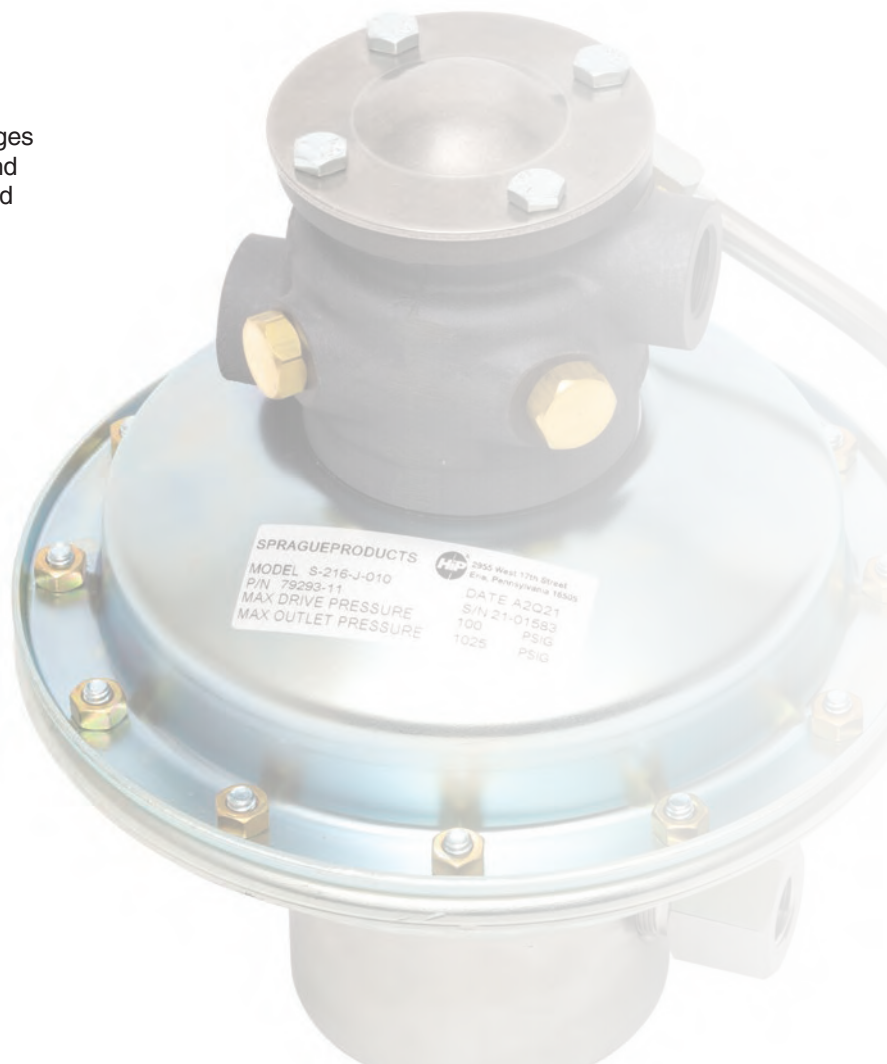

How Sprague Air Driven Hydraulic Pumps Work

The Sprague pump develops high output pressures by applying the principle of differential areas. The pump has a large area air piston, air driven at low pressures. This air piston drives a small area liquid piston that in turn pumps liquids at high pressures.

The liquid output pressure is determined by the ratio between the area of the air drive piston, the area of the liquid driven piston and the applied operating air pressure.

The area relationship of the air piston to the liquid piston is referred to as the pump ratio. This pump ratio is indicated in the dash number which follows the pump model basic number.

Example: S-216-J-10 pump has an approximate ratio of 10 to 1 or 10 psi liquid pressure for each 1 psi of operating air pressure.

In operation, an S-216-J-10 pump using 100 psi of input air pressure will produce a maximum liquid output pressure of 1000 psi; 80 psi air will produce an output pressure of 800 psi; 60 psi air . . . 600 psi output, and 40 psi air . . . 400 psi output.

By regulating the incoming air supply at the pressure regulator, the liquid output can be infinitely adjusted through the pump's pressure range.

Wetted Section Materials

The materials used in the wetted section of the Sprague basic pump are compatible to most liquids to be serviced.

Pump components and materials include:

Liquid Body	303 Stainless steel
Liquid (driven) Piston	416 Stainless steel chrome plated
Piston O-ring	Nitrile
Piston Back-up Ring	Teflon® or equivalent compound
Check Valve Body	416 Stainless steel
Check Valve Poppet	17-4ph Stainless steel
Check Valve Spring	302 Stainless steel
Check Valve Seal	Nitrile

Teflon is a registered trademark of the DuPont Company

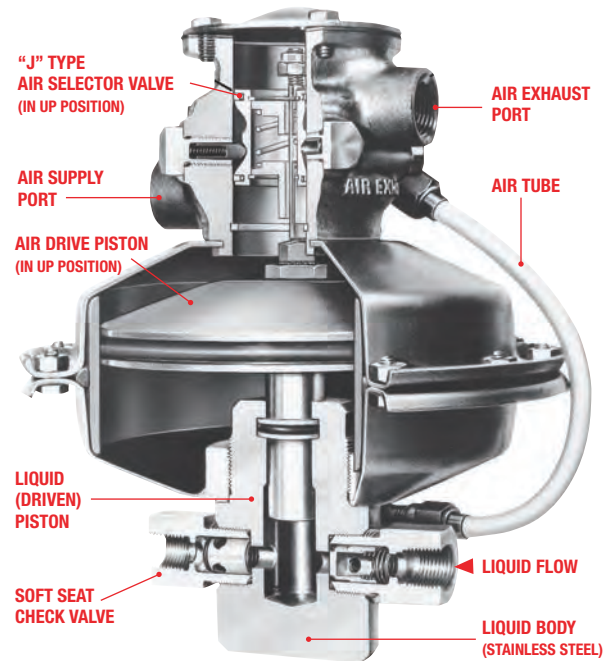

Pump Air Piston in UP Position

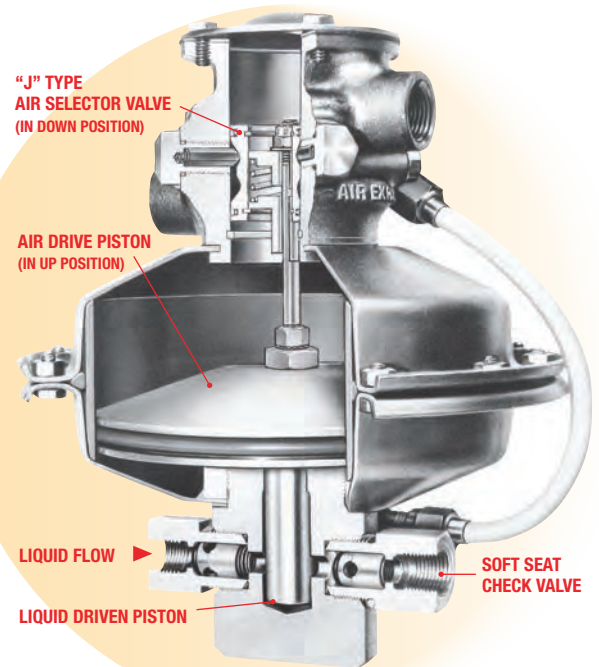

Pump Air Piston in DOWN Position

Accessories

For optimum efficiency, certain accessories are recommended for use with pump. Noise can be dampened by installing muffler at pump's air exhaust port. For "J" type lubricated pumps, install an air control unit (filter, pressure regulator with air gauge and lubricator) in the supply line. For "JN" type non-lubricated pumps and boosters, install an air control unit (without lubricator) in the air supply line. These and other related accessory items are available from HiP.

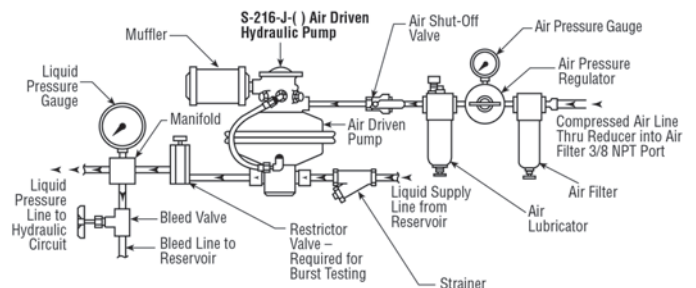

Pump & Accessories – Typical Arrangement

Ordering Information

Sprague Part Number System

The Sprague J and JB series pumps all start with S-216 as a standard part number. These pumps feature a 6 inch drive piston and are offered in the following nominal ratios:

10:1, 20:1 & 30:1 – J pumps

35:1, 60:1 & 100:1 – J pumps or JB pumps

101:1, 125:1, 150:1, 200:1 & 300:1 – JB pumps

JB series pumps include a bushing for improved wear life. The J and JB pump standard models are intended for use with lubricated air. The following optional configurations are also available:

- N** = Standard, non-lubricated air
- D** = Double-acting, lubricated air
- DN** = Double-acting, non-lubricated air
- R** = Standard with reservoir, lubricated air
- NR** = Standard with reservoir, non-lubricated air
- S** = Non-contaminating, separated, lubricated air
- SN** = Non-contaminating, separated, non-lubricated air

The appropriate letter(s) for these options are added directly after the J or JB pump is specified (see below). A dash follows and then a number which indicates the pump or booster nominal pump ratio.

Example: S-216-J-60 = 60:1 pump nominal ratio.

-HO = For increased flow capacity, high output pumps are also available, indicated after the ratio.



2

How to Order Pumps

To order a hydraulic pump or power unit, select a pump ratio based on the liquid pressure and flow requirements and the available air pressure to operate the pump. Refer to the Pump Ratio Selection Charts on page 17.

By adjusting the driving air supply at the pressure regulator, the pump can produce any liquid output pressure between 25% and 100% of rated pressure.

For example, a separated, non-lubricated pump is desired for a system requiring 1,000 psi liquid discharge pressure with a 170 cubic inch per minute flow rate capacity, with an available air supply of 100 psi. From the Chart on page 17, a suitable pump nominal ratio will be 35:1.

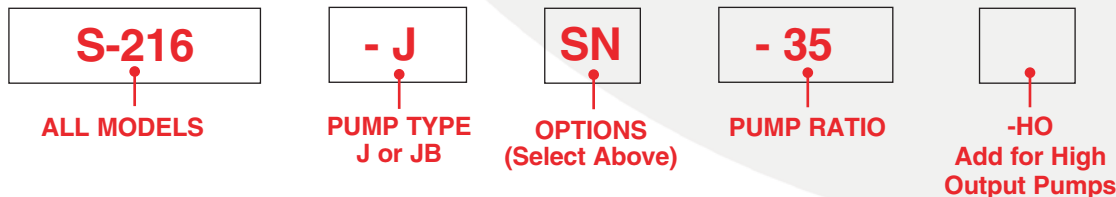

The part number for this pump would be: **S-216-JSN-35**

Notes:

- The standard S-216-J pump has a stainless-steel liquid body and is furnished with nitrile O-rings.
- JB series pumps use a wear resistant polyurethane piston seal to reduce maintenance frequency.
- Sprague pumps can also be furnished with other O-ring materials including FKM, Neoprene, EPR. Consult factory for other soft seal compounds. For questions regarding liquid/seal compatibility, contact Sprague Products for recommendations for the seal compound suited to the application.

Pump Ratio Selection Chart

for the Following Pump Models: S-216-J, S-216-JN, S-216-JS and S-216-JSN

100 psi Driving Air Supply			Capacities - cubic inches / minute nominal																							Max Flow
			Liquid Discharge Pressure - psi																							
Nom. Ratio	Max. Output Pressure psi	Displacement per Stroke CU. IN.	0	250	500	750	1000	1500	2000	2500	3000	4000	5000	7500	9000	10000	12500	15000	17500	20000	22500	25000	27500	30000	32500	
10	1025	3.26	457.0	433.1	374.7	278.4																				457.0
20	1910	1.75	450.4	423.6	362.4	301.3	257.9	144.1																		450.4
30	3200	1.04	332.0	288.3	242.2	208.0	191.0	157.2	119.0	64.9	24.5															332.0
35	4760	0.708	298.9	222.9	199.0	176.3	171.3	154.3	125.6	109.9	89.0	25.0														298.9
60	6330	0.527	213.0	178.3	161.6	146.3	137.5	123.5	113.5	100.1	87.7	63.3	35.0													213.0
100	9100	0.366	160.4	131.0	119.5	113.7	107.3	99.5	89.6	82.5	75.9	64.4	51.4	15.3												160.4
101	10000	0.33	122.0	122.0	122.0	121.4	120.6	119.1	114.7	108.9	102.9	92.3	81.8	55.7	33.2											122.0
125	12400	0.266	103.5	99.6	95.8	93.0	90.2	83.3	76.4	75.7	74.9	65.2	56.3	41.5	33.5	28.1										103.5
150	16200	0.205	78.0	77.0	76.0	74.0	72.0	69.0	66.0	63.0	60.0	56.0	53.0	44.5	37.6	33.0	24.5	12.2								78.0
200	24900	0.132	53.0	51.5	50.0	49.0	48.0	47.0	46.0	44.5	43.0	41.0	38.0	34.0	31.6	30.0	23.9	20.0	15.6	13.8	11.5					53.0
300	36500	0.092	37.0	36.0	35.0	34.0	33.0	32.5	32.0	31.5	31.0	30.0	28.2	26.2	23.7	22.0	20.2	18.3	16.2	13.8	12.2	10.0	8.0	5.5	2.1	37.0

2

6.9 bar Driving Air Supply			Capacities - cc / minute nominal																							Max Flow
			Liquid Discharge Pressure - bar																							
Nom. Ratio	Max Output Pressure bar	Displacement per Stroke cc	0	17	34	52	69	103	138	172	207	276	345	517	621	690	862	1034	1207	1379	1551	1724	1896	2069	2241	
10	71	53.4	7489	7097	6140	4563																				7489
20	132	28.7	7382	6942	5939	4937	4227	2362																		7382
30	221	17.0	5441	4725	3969	3409	3130	2576	1950	1064	401															5441
35	328	11.6	4899	3653	3262	2889	2807	2529	2058	1801	1458	410														4899
60	436	8.6	3490	2922	2649	2397	2254	2024	1860	1640	1437	1037	573													3490
100	627	6.0	2628	2147	1959	1863	1758	1631	1468	1352	1244	1055	843	251												2628
101	690	5.4	2000	2000	2000	1990	1977	1951	1880	1784	1687	1513	1340	913	544											2000
125	855	4.4	1696	1633	1570	1524.5	1479	1365.5	1252	1240	1228	1068	923	680	548.6	461										1696
150	1117	3.4	1278	1261.5	1245	1212.5	1180	1131	1082	1032.5	983	918	869	730	616	540	402	200								1278
200	1717	2.2	869	844	819	803	787	770.5	754	729.5	705	672	623	557	518	492	392	328	255	226	188					869
300	2517	1.5	606	590	574	557.5	541	532.5	524	516	508	492	462	429	387.6	360	331	300	266	226	200	164	131	90	35	606

High Pressure Connections

All pumps that are capable of pressures exceeding 10,000 psi are equipped with 9/16-18 HF4 outlet check valves that accept coned and threaded tube fittings.

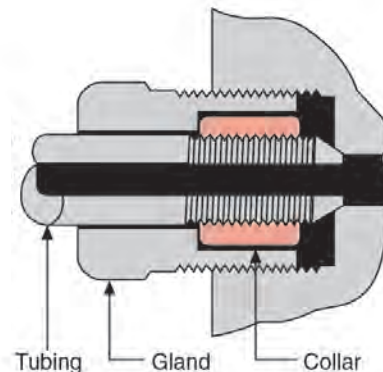

S-216-J Standard Pump

and S-216-JN Non-Lubricated Pump

2

S-216-J(-) STANDARD PUMP, LUBRICATED

This general use, air driven pump produces medium to high liquid pressures and services oil, water and compatible chemicals.

The Model S-216-J standard pump is offered in ten ratios (area of large air piston to area of small liquid piston) ranging from the 10:1 ratio pump which develops up to 1025 psi (70 bar) to the 300:1 ratio which develops up to 36,500 psi (2516 bar). By regulating the driving air pressure, the pump's liquid output can be adjusted through its pressure range.

The pump's wetted section components are stainless steel, compatible with most non-abrasive liquids.

Being air driven, the pump is safe for use in hazardous areas.

The S-216-J standard pump requires lubricated driving air to lubricate the pump's dynamic air seals and other internal parts within the air portion of the pump.

When determining the appropriate pump nominal ratio to order, refer to page 16-17, How To Order Pumps and Pump Ratio Selection Chart.

Example: S-216-J-60
 Pump Model Number Pump Nominal Ratio



S-216-J(-)

S-216-J

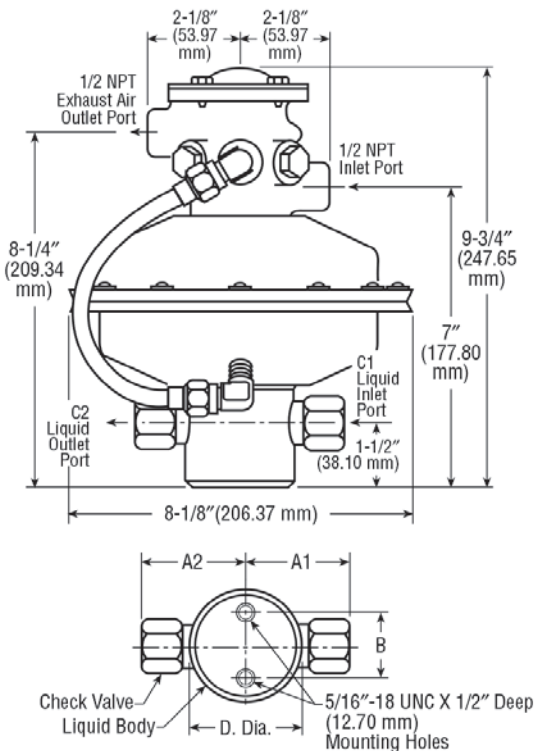

Nominal Ratio	A		B		C1	C2	D/Dia.	
	Inch	mm	Inch	mm	Inlet	Outlet	Inch	mm
10:1	2-29/32	73.82	2-7/16	61.90	NFC	NFC	3-1/2	88.86
20:1	2-29/32	73.82	2-7/16	61.90	NFC	NFC	3-1/4	82.51
30:1	2-29/32	73.82	2-7/16	61.90	NFC	NFC	3-1/4	82.51
35:1	2-3/8	57.15	1-1/2	38.10	NFC	NFC	2-1/2	63.47
60:1	2-3/8	57.15	1-1/2	38.10	NFC	NFC	2-1/2	63.47
100:1	2-3/8	57.15	1-1/2	38.10	NFC	NFC	2-1/2	63.47
101:1	2-3/8	60.45	1-1/2	38.10	NFC	NFC	2-1/2	63.47
125:1	2-1/4	57.15	1-1/2	38.10	NFB	HF4	2-1/2	63.47
150:1	2-1/4	57.15	1-1/2	38.10	NFB	HF4	2-1/2	63.47
200:1	2-1/4	57.15	1-1/2	38.10	NFB	HF4	2-1/2	63.47
300:1	2-1/4	57.15	1-1/2	38.10	NFB	HF4	2-1/2	63.47

Pump Model No.	Part Number	Maximum Output		Port Threads			Actual Weight	
		psi	bar	Driving Air	Inlet	Outlet	lbs.-oz.	kg
S-216-J-10	79293-11	1025	70	1/2 NPT	NFC	NFC	16-4	7.4
S-216-JN-10	89842-11	1025	70	1/2 NPT	NFC	NFC	16-4	7.4
S-216-JR-10	91612-11	1025	70	1/2 NPT	NFC	NFC	24-4	11
S-216-JNR-10	91613-11	1025	70	1/2 NPT	NFC	NFC	24-4	11
S-216-J-20	77894-11	1910	131	1/2 NPT	NFC	NFC	14-8	6.6
S-216-JN-20	89842-21	1910	131	1/2 NPT	NFC	NFC	14-8	6.6
S-216-JR-20	91612-21	1910	131	1/2 NPT	NFC	NFC	22-8	10.2
S-216-JNR-20	91613-21	1910	131	1/2 NPT	NFC	NFC	22-8	10.2
S-216-J-30	77894-21	3200	220	1/2 NPT	NFC	NFC	14-8	6.6
S-216-JN-30	89842-31	3200	220	1/2 NPT	NFC	NFC	14-8	6.6
S-216-JR-30	91612-31	3200	220	1/2 NPT	NFC	NFC	22-8	10.2
S-216-JNR-30	91613-21	3200	220	1/2 NPT	NFC	NFC	22-8	10.2
S-216-J-035	77895-81	4760	328	1/2 NPT	NFC	NFC	12-8	5.7
S-216-JN-035	89842-41	4760	328	1/2 NPT	NFC	NFC	12-8	5.7
S-216-JR-035	91612-41	4760	328	1/2 NPT	NFC	NFC	20-8	9.3
S-216-JNR-035	91613-41	4760	328	1/2 NPT	NFC	NFC	20-8	9.3
S-216-JB-035	94186-035-01	4760	328	1/2 NPT	NFC	NFC	12-8	5.7
S-216-JBN-035	94198-035-01	4760	328	1/2 NPT	NFC	NFC	12-8	5.7
S-216-JBR-035	94242-035-01	4760	328	1/2 NPT	NFC	NFC	20-8	9.3
S-216-JBNR-035	94243-035-01	4760	328	1/2 NPT	NFC	NFC	20-8	9.3
S-216-J-060	77895-11	6330	436	1/2 NPT	NFC	NFC	12-8	5.7
S-216-JN-060	89842-51	6330	436	1/2 NPT	NFC	NFC	12-8	5.7
S-216-JR-060	91612-51	6330	436	1/2 NPT	NFC	NFC	20-8	9.3
S-216-JNR-060	91613-51	6330	436	1/2 NPT	NFC	NFC	20-8	9.3
S-216-JB-060	94186-060-01	6330	436	1/2 NPT	NFC	NFC	12-8	5.7
S-216-JBN-060	94198-060-01	6330	436	1/2 NPT	NFC	NFC	12-8	5.7
S-216-JBR-060	94242-060-01	6330	436	1/2 NPT	NFC	NFC	20-8	9.3
S-216-JBNR-060	94243-060-01	6330	436	1/2 NPT	NFC	NFC	20-8	9.3
S-216-J-100	77895-21	9100	627	1/2 NPT	NFC	NFC	12-8	5.7
S-216-JN-100	89842-61	9100	627	1/2 NPT	NFC	NFC	12-8	5.7
S-216-JR-100	91612-61	9100	627	1/2 NPT	NFC	NFC	20-8	9.3
S-216-JNR-100	91613-61	9100	627	1/2 NPT	NFC	NFC	20-8	9.3
S-216-JB-100	94186-100-01	9100	627	1/2 NPT	NFC	NFC	12-8	5.7
S-216-JBN-100	94198-100-01	9100	627	1/2 NPT	NFC	NFC	12-8	5.7
S-216-JBR-100	94242-100-01	9100	627	1/2 NPT	NFC	NFC	20-8	9.3
S-216-JBNR-100	94243-100-01	9100	627	1/2 NPT	NFC	NFC	20-8	9.3
S-216-JB-101	94186-101-01	10000	689	1/2 NPT	NFC	NFC	12-8	5.7
S-216-JBN-101	94198-101-01	10000	689	1/2 NPT	NFC	NFC	12-8	5.7
S-216-JBR-101	94242-101-01	10000	689	1/2 NPT	NFC	NFC	20-8	9.3
S-216-JBNR-101	94243-101-01	10000	689	1/2 NPT	NFC	NFC	20-8	9.3
S-216-JB-125	94186-125-11	12400	854	1/2 NPT	NFB	HF4	12-8	5.7
S-216-JBN-125	94198-125-11	12400	854	1/2 NPT	NFB	HF4	12-8	5.7
S-216-JBR-125	94242-125-11	12400	854	1/2 NPT	NFB	HF4	12-8	5.7
S-216-JBNR-125	94243-125-11	12400	854	1/2 NPT	NFB	HF4	12-8	5.7
S-216-JB-150	94186-150-11	16200	1116	1/2 NPT	NFB	HF4	12-8	5.7
S-216-JBN-150	94198-150-11	16200	1116	1/2 NPT	NFB	HF4	12-8	5.7
S-216-JBR-150	94242-150-11	16200	1116	1/2 NPT	NFB	HF4	20-8	9.3
S-216-JBNR-150	94243-150-11	16200	1116	1/2 NPT	NFB	HF4	20-8	9.3
S-216-JB-200	94186-200-11	24900	1716	1/2 NPT	NFB	HF4	12-8	5.7
S-216-JBN-200	94198-200-11	24900	1716	1/2 NPT	NFB	HF4	12-8	5.7
S-216-JBR-200	94242-200-11	24900	1716	1/2 NPT	NFB	HF4	20-8	9.3
S-216-JBNR-200	94243-200-11	24900	1716	1/2 NPT	NFB	HF4	20-8	9.3
S-216-JB-300	94186-300-11	36500	2516	1/2 NPT	NFB	HF4	12-8	5.7
S-216-JBN-300	94198-300-11	36500	2516	1/2 NPT	NFB	HF4	12-8	5.7
S-216-JBR-300	94242-300-11	36500	2516	1/2 NPT	NFB	HF4	20-8	9.3
S-216-JBNR-300	94243-300-11	36500	2516	1/2 NPT	NFB	HF4	20-8	9.3

S-216-JN-() STANDARD PUMP, NON-LUBRICATED

Mechanically the same as the S-216-J standard pump, this S-216-JN-() pump is suitable for use in cleanrooms or laboratories. The pump uses normal shop compressed air without lubrication to actuate the pump. Its dynamic air seals are self lubricating. The pump's exhaust air is identical to the driving air supply, so no additional contaminants are added to the exhaust air. Order in the same manner as the S-216-J and add an "N" to model number.

Example: S-216-JN-60
 Pump Model Number | Pump Nominal Ratio

S-216-J-()HO HIGH OUTPUT PUMP, LUBRICATED
S-216-JN-()HO HIGH OUTPUT PUMP, NON-LUBRICATED

Mechanically the same as the S-216-J-() or S-216-JN-() pumps, the S-216-()-()HO pumps utilize larger air to

dramatically increase pump speeds. Flows of up to double the standard published flow rates are available with the high output pumps.

S-216-JR-() STANDARD PUMP/RESERVOIR, LUBRICATED

This pump assembly combines the S-216-J standard pump (lubricated air type) with a one-gallon (3.8 liters) steel reservoir. Readily adaptable to portable power pack use or suitable for stationary use to provide hydraulic power for production machinery or for hydrostatic testing. Available in ten pump ratios.

S-216-JNR-() PUMP/RESERVOIR, NON-LUBRICATED

Same as S-216-JR-() assembly except that the S-216-JN-() standard pump (non-lubricated air type) is used. No additional contaminants are exhausted from the pump. Available in ten pump ratios.

S-216-J Flow Performance

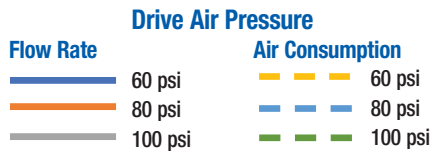
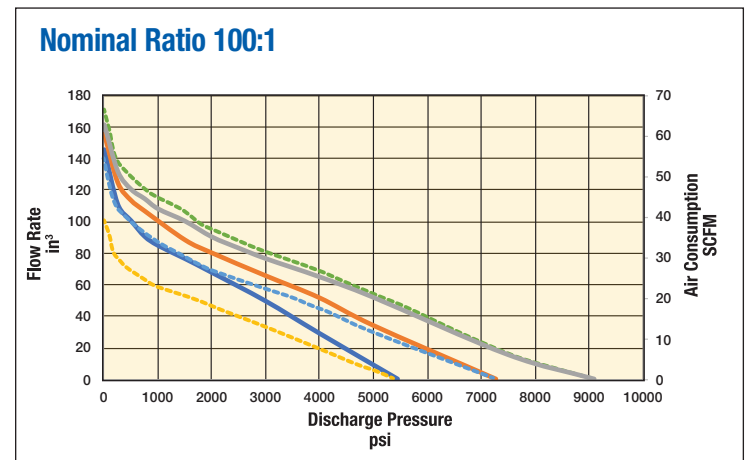
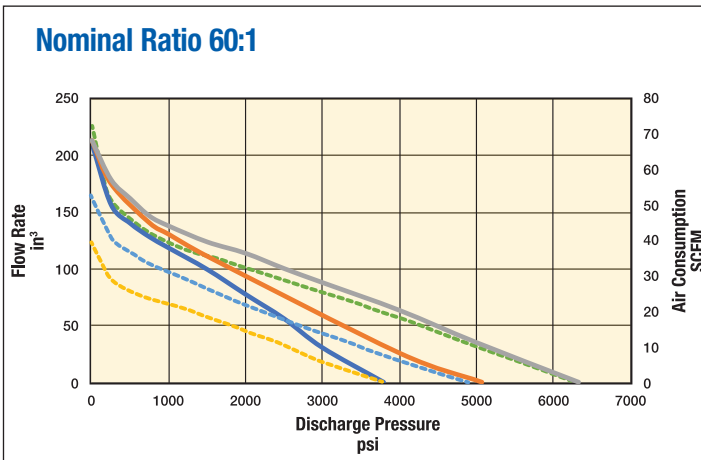
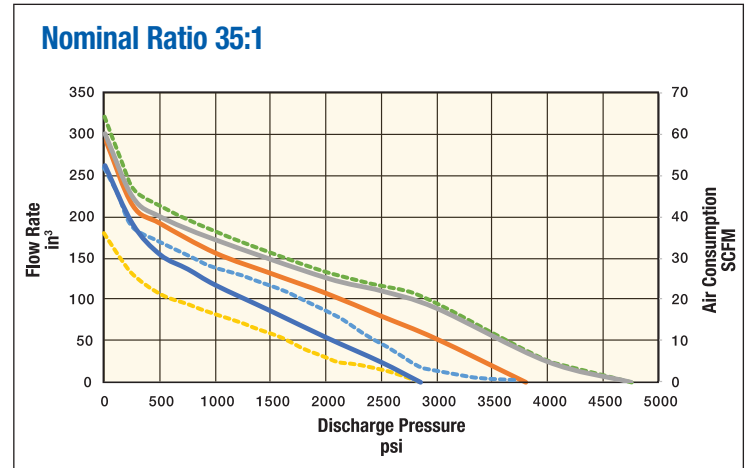
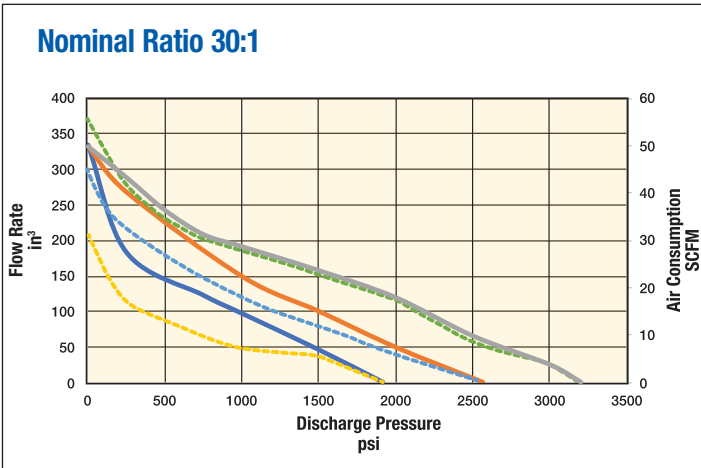
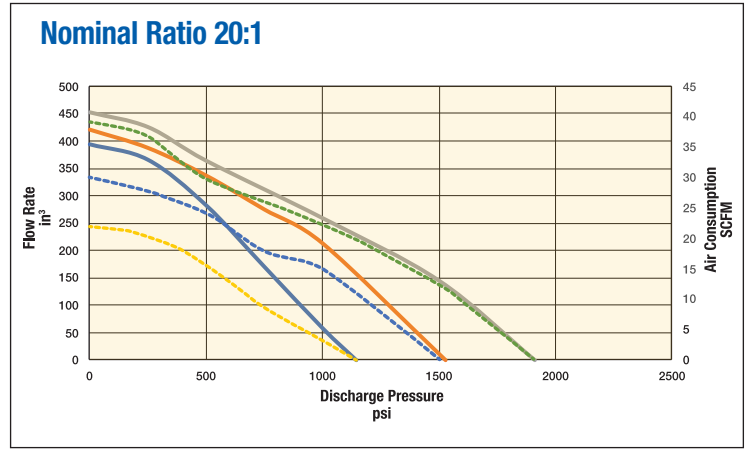
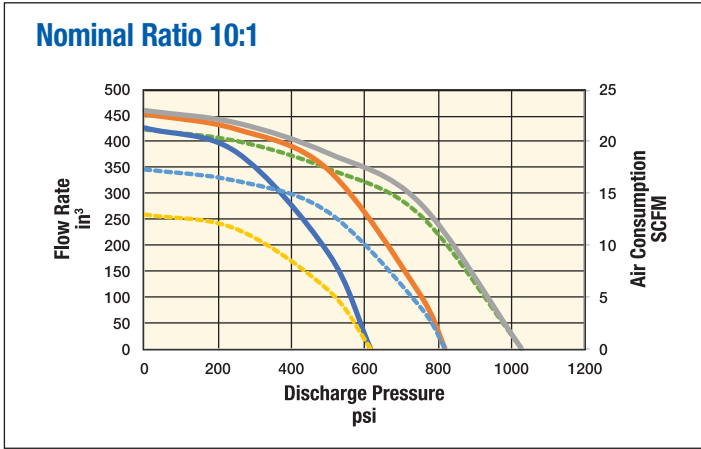

S-216-J Flow Performance (cont.)

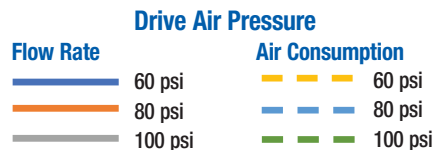
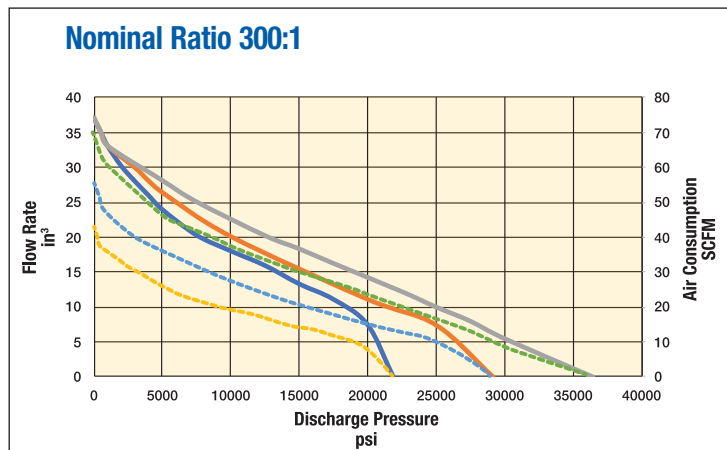
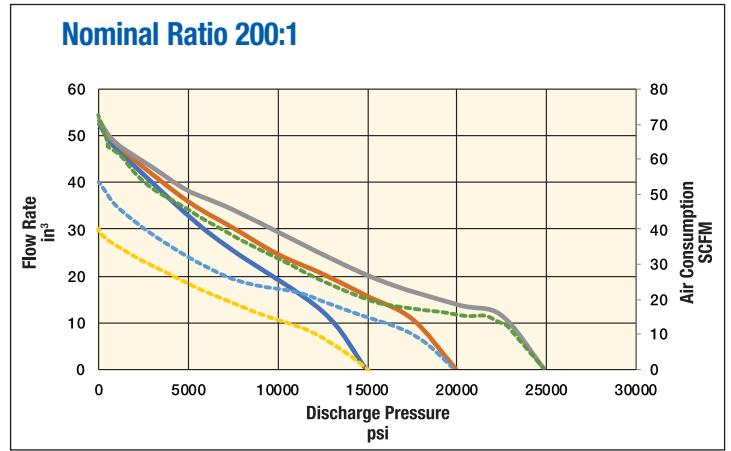
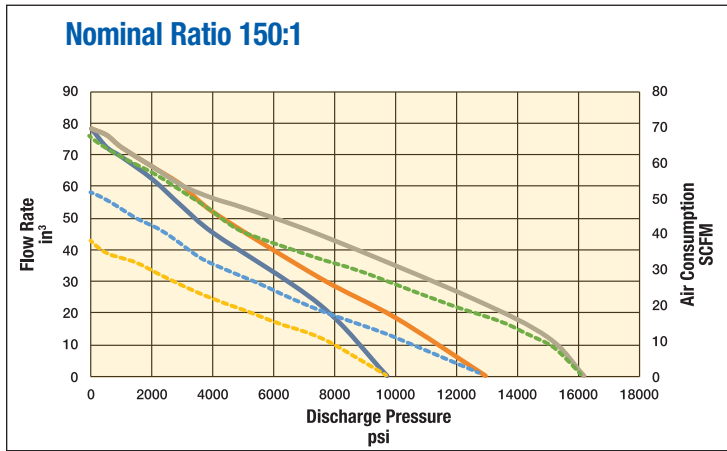
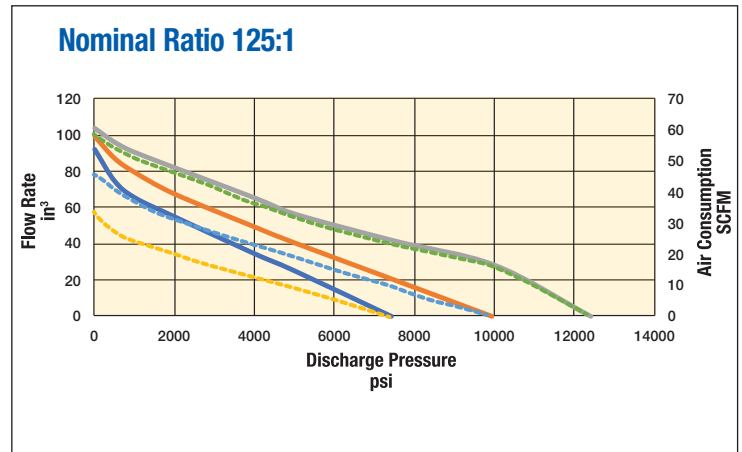
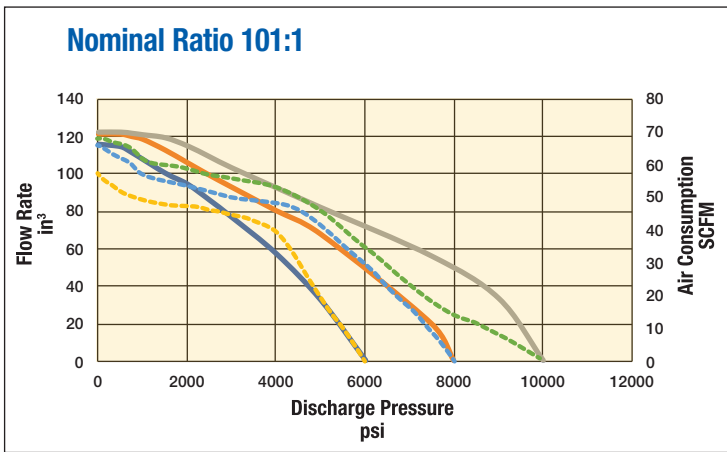

Double Acting JD Pump

Class 1 J Series

These Sprague hydraulic pumps move relatively large flows of liquids at low to moderate pressures. The pumps deliver liquid with each up and down stroke of the liquid piston rather than, only with a down stroke like other J pumps. The pump's air-driving action is the same as the Sprague air driven S-216-J series hydraulic pumps described on page 18. Being air driven, these double-acting pumps are non-arcing and non-sparking, safe for use in hazardous or confined areas.

See Charts on page 17 for liquid discharge rates and pressures. See page 60 for power unit arrangements of these pump models.

2

S-216-JD-6.8

Services oil and non-corrosive liquids. **Not for water service.** With a 6.8 pumping ratio, this double-acting pump is well suited for liquid transfer, low pressure hydrostatic testing and other industrial uses.

This pump discharges volume liquids up to 12 gallons per minute and provides for selected discharge pressures up to 680 psi. With its liquid body and main components made from anodized aluminum alloy, the pump is reduced in weight and lower in cost. The standard pump's special seals in the wetted section are compatible with a wide range of chemicals while other seals in the pump are nitrile. Other seal compounds are optional.

S-216-JD-34

Services oil, water and many corrosive liquids. With a 34 to 1 pumping ratio, this double-acting pump discharges volume liquids at any selected pressure up to 3,400 psi, suitable to many industrial applications requiring volume liquid delivery at higher pressures and holding cycles.

This pump uses an internal check valve in its liquid piston head, to obtain a double-acting, steady flow of liquid. This unique design results in higher pressures and uses material resistant to many corrosive liquids. The pump has special dynamic seals to accommodate low lubricity liquids. The pump body is brass. Mounting brackets facilitate installation.

S-216-JD-36

Services oil and non-corrosive liquids. **Not for water service.** Its general design is identical to the S-216-JD-34 pump described above. The -36 pump has an aluminum body which significantly lowers the price of the pump and reduces its weight by four pounds. The pump has nitrile seals.

S-216-JD-60

Non-contaminating pump for cleanroom or laboratory use has self-lubricating dynamic seals. The pump uses clean, dry driving air.



S-216-JD(-)

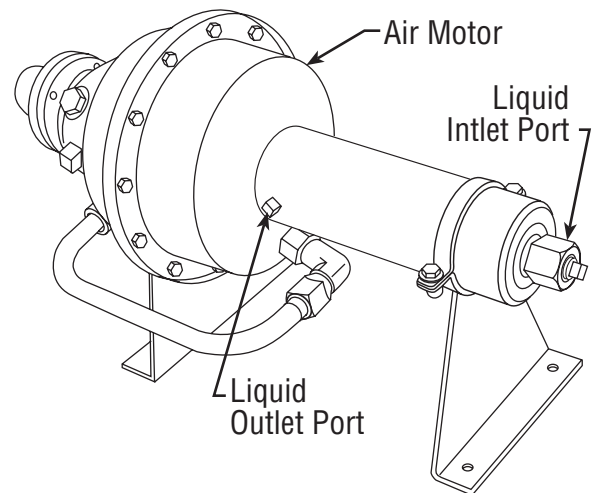

Double Acting JD Pump - Dimensions

	S-216-JD-6.8	S-216-JD-34	S-216-JD-36	S-216-JD-60	S-216-JDN-60
Height:	8.3 in. (21.08 cm)	10-1/4 in. (26.0 cm)	10-1/4 in. (26.0 cm)	10-1/2 in. (26.7 cm)	10-1/2 in. (26.7)
Length:	15.75 in. (40.01 cm)	20-1/4 in. (51.4 cm)	20-1/4 in. (51.4 cm)	20-3/4 in. (52.7)	20-3/4 in. (52.7)
Width:	8 in. (20.32 cm)	8-1/8 in. (21.6 cm)	8-1/8 in. (21.6 cm)	8-1/8 in. (20.6 cm)	8-1/8 in. (20.6 cm)
Reference:	90615	89320-1	81557-20	90977-2	91616

Pump Model Number	Displacement per cycle (Cu. Inch)	DISCHARGE CAPACITY - gallons per minute, approximate, based on 50 SCFM* of driving air at 100 psi										
		Discharge Pressure - psi										
		0	100	250	350	500	1000	2000	3000	4000	5000	6000
S-216-JD-6.8	9.72	12.00	10.9	8.6	7.0	4.0						
S-216-JD-34	4.90	3.1	2.95	-	2.9	2.85	2.7	2.1	1.1			
S-216-JD-36	4.90	2.9	-	2.1	-	1.98	1.74	1.23	0.6			
S-216-JD-60*	2.82	-	-	-	-	2.23	2.10	1.84	1.44	1.07	0.71	0.14

*Discharge capacity of S-216-JD-60 is based on 85 SCFM of driving air at 100 psi.

Pump Model Number	Displacement per cycle (liters)	DISCHARGE CAPACITY -liters per minute, approximate, based on 1.4 cubic meters* per minute of driving air at 6.9 bar										
		Discharge Pressure - psi										
		0	6.9	17.2	24.1	34.5	69	138	207	275	345	414
S-216-JD-6.8	0.159	45.1	41.3	32.5	26.5	15.1						
S-216-JD-34	0.080	11.7	11.1	-	10.9	10.8	10.2	7.9	4.2			
S-216-JD-36	0.080	11.0	-	7.9	-	7.5	6.6	4.7	2.3			
S-216-JD-60*	0.462	-	-	-	-	8.44	7.95	6.96	5.45	4.05	2.69	0.53

*Discharge capacity of S-216-JD-60 is based on 2.41 cubic meters per minute of driving air at 6.9 bar.

Separated JS Pumps

Non-Contaminating

S-216-JS-()

The design feature of this “JS” type pump is the mechanical separation of the liquid portion from the air driven portion of the pump. This allows the pump to service contaminate-free fluids or fluids for human consumption.

Other applications may include liquids for food processing, liquids for atomic energy use, proof testing of pressure vessels such as oxygen and nitrogen bottles, injecting corrosive inhibitors into pipe lines or for other specialized uses.

The mechanical separation prevents undesirable elements or contaminants, normally present in compressed air or lubricants, from contacting the contaminate-free liquid being pumped. The separation also permits removal of the stainless steel liquid body (same body as S-216-J pump) for service or substitution with optional liquid bodies and liquid pistons to change the rated output pressure without disturbing the pump’s driving side. Refer to the Pump Ratio Selection Charts, page 17.

Like the “J” type basic pump, this “JS” pump uses lubricated driving air for the air driven portion of the pump. Mounting brackets are included as part of the pump assembly.

S-216-JSN-()

This pump is suitable for cleanroom or laboratory use. It has the same mechanical separation features as the model S-216-JS pump. Additionally, the “JSN” pump uses clean, dry air; thus no contaminants are added to the pump’s exhaust air. The air section of the pump has self-lubricating seals.



S-216-JS-()

Pump Model No.	Part Number	Pump Maximum Output (See Note)		Ports		
		psi	bar	Driving Air	Liquid Inlet	Liquid Outlet
S-216-JS-10	79557-21	1025	71	1/2 NPT	NFC	NFC
S-216-JSN-10	90067-11	1025	71	1/2 NPT	NFC	NFC
S-216-JS-20	77896-61	1910	132	1/2 NPT	NFC	NFC
S-216-JSN-20	90067-21	1910	132	1/2 NPT	NFC	NFC
S-216-JS-30	77896-71	3200	221	1/2 NPT	NFC	NFC
S-216-JSN-30	90067-31	3200	221	1/2 NPT	NFC	NFC
S-216-JBS-35	94230-035-01	4760	328	1/2 NPT	NFC	NFC
S-216-JBSN-35	94233-035-01	4760	328	1/2 NPT	NFC	NFC
S-216-JBS-60	94230-060-01	6330	436	1/2 NPT	NFC	NFC
S-216-JBSN-60	94233-060-01	6330	436	1/2 NPT	NFC	NFC
S-216-JBS-100	94230-100-01	9100	627	1/2 NPT	NFC	NFC
S-216-JBSN-100	94233-100-01	9100	627	1/2 NPT	NFC	NFC
S-216-JBS-101	94230-101-01	10000	689	1/2 NPT	NFC	NFC
S-216-JBSN-101	94233-101-01	10000	689	1/2 NPT	NFC	NFC
S-216-JBS-125	94230-125-11	12400	855	1/2 NPT	NFB	HF4
S-216-JBSN-125	94233-125-11	12400	855	1/2 NPT	NFB	HF4
S-216-JBS-150	94230-150-11	16200	1117	1/2 NPT	NFB	HF4
S-216-JBSN-150	94233-150-11	16200	1117	1/2 NPT	NFB	HF4
S-216JBS-200	94230-200-11	24900	1717	1/2 NPT	NFB	HF4
S-216-JBSN-200	94233-200-11	24900	1717	1/2 NPT	NFB	HF4
S-216JBS-300	94230-300-11	36500	2517	1/2 NPT	NFB	HF4
S-216-JBSN-300	94233-300-11	36500	2517	1/2 NPT	NFB	HF4

GJC Double Acting

10.5 HP Pumps

S-218-GJC-()

This 10.5 hp, double-acting piston pump services oil, water and compatible chemicals. It is ideal for hydrostatic testing, machine operations, charging accumulators and for deep-hole applications.

Offered in three pumping ratios (45:1, 65:1 and 200:1), the S-218 pump produces medium to high pressures for controlled flow or for holding pressures. By regulating the air supply, liquid outlet pressure can be infinitely adjusted throughout the pump's pressure range.

Being air-driven, the pump is safe for use in hazardous areas. It can be used in a wide variety of temperatures and in other hostile environments. The standard pump uses a lubricated driving air supply.

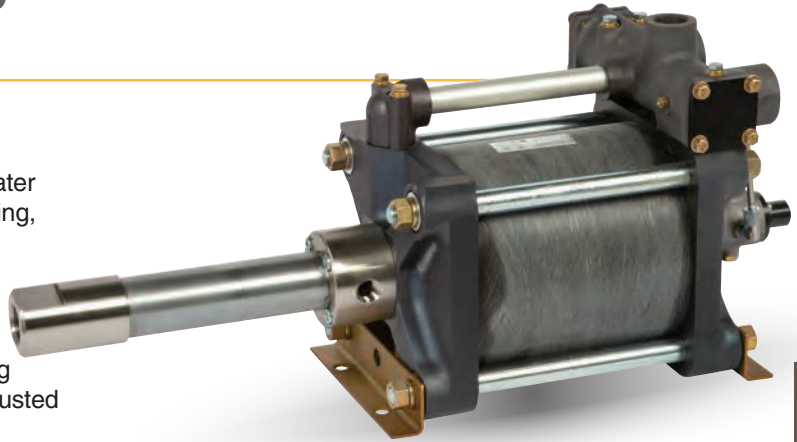

S-218-GJC-()

2

Other Features

Pumps rapidly to desired pressure. Holds pressure indefinitely with minimal energy consumption, no increase in liquid temperature or parts movement. Automatically restarts to restore pressure balance when imbalance occurs.

Liquid pumping section materials are stainless steel and chrome-plated steel, both compatible with most non-abrasive liquids.

Air motor has water emitters to prevent water from collecting in humid conditions.

Can be driven with wellhead gases. Can operate in freezing or hostile conditions because of anti-icing device.

Safe for use in hazardous conditions because there are no electrical sparking risks or electrical connections.

S-218-GJC-45

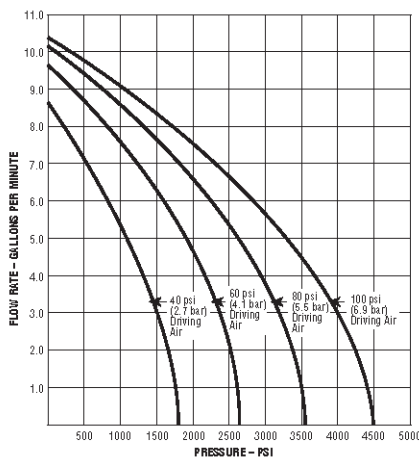

S-218-GJC-65

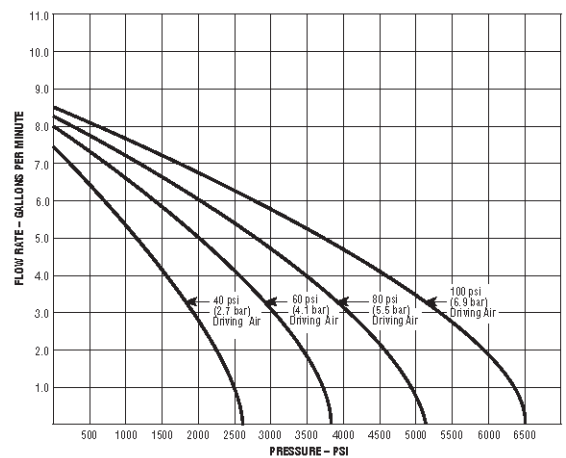

S-218-GJC Pumps (45 & 65)	
Length:	29 in. (73.6 cm)
Width:	10-5/8 in. (27.0 cm)
Height:	12-1/2 in. (31.8 cm)
Air Inlet Port:	1 NPT
Liquid Inlet Port:	1 NPT
Liquid Outlet Port:	1/2 NPT
Reference:	1 NPT
-45	90226-1
-60	90225-1
-200	

Pump Model Number	DISCHARGE CAPACITY - GALLONS (liters) PER MINUTE - APPROXIMATE Based on 350 SCFM of driving air at 100 psi (9.9 Std. Cu. Meters driving air at 6.9 bars)									
	0 psi (0 bar)	500 psi (34.5 bar)	1000 psi (69 bar)	2000 psi (138 bar)	3000 psi (207 bar)	4000 psi (276 bar)	4500 psi (310 bar)	5000 psi (345 bar)	5500 psi (379.5 bar)	6000 psi (414 bar)
S-218-GJC-45 (45:1 ratio)	10.5 gal (39.7)	9.8 (37.1)	9.2 (34.8)	7.7 (29.1)	5.8 (22.0)	3.1 (11.7)	-	-	-	-
S-218-GJC-65 (65:1 ratio)	8.5 (32.2)	8.0 (30.3)	7.6 (28.8)	6.6 (25.0)	5.6 (21.2)	4.5 (17.0)	3.9 (14.8)	3.3 (12.5)	2.7 (10.2)	1.9 (7.2)

S-218 Double Ended Pump

Single Acting

S-218-200D

The S-218-200D air-driven, double ended pump produces high pressure liquid flows up to 2-1/2 gallons per minute and pressures up to 20,000 psi.

The pump services water, oil and compatible chemicals.

Features

Has fewer moving parts and seals than comparable pumps... thus less maintenance. Safe for use in hazardous areas... no electrical connections.

Pump ideal for hydrostatic testing or water jet applications.

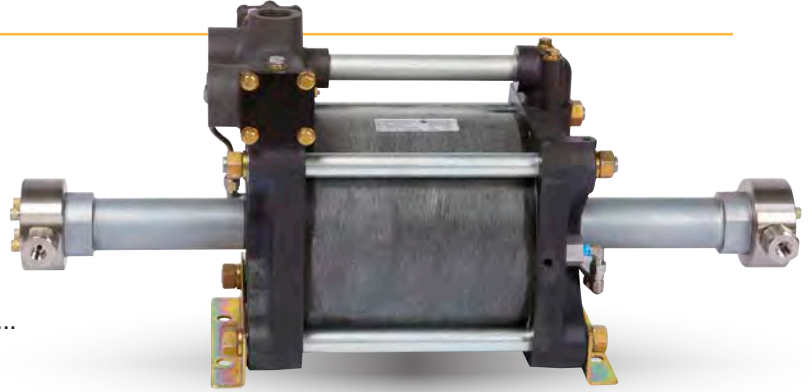

S-218-200D

2

S-218-200D

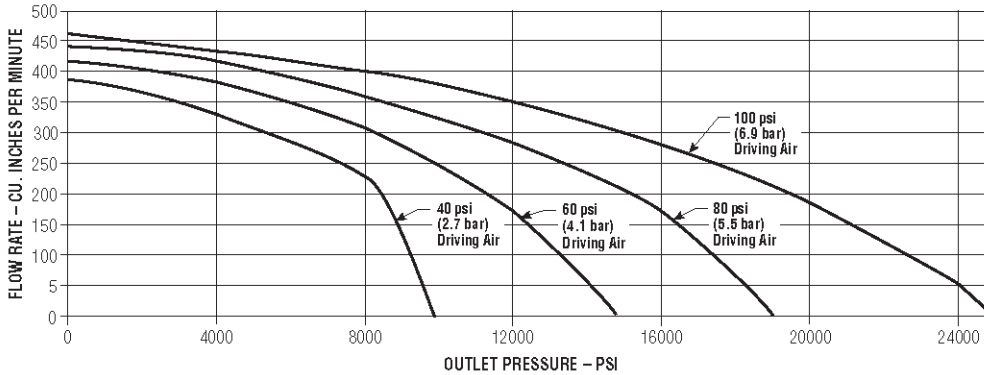

S-218 Pumps (200D)	
Length:	28.5 in. (72.4 cm)
Width:	10-5/8 in. (27.0 cm)
Height:	12-1/2 in. (31.8 cm)
Air Inlet Port:	1 NPT
Liquid Inlet Port:	1/2 NPT
Liquid Outlet Port:	HF4 (3/8 in. OD)

Pump Model Number	DISCHARGE CAPACITY - CUBIC INCHES (liters) PER MINUTE - APPROXIMATE Based on 350 SCFM of driving air at 100 psi (9.9 Std. Cu. Meters driving air at 6.9 bars)					
	0 psi (0 bar)	4000 psi (276 bar)	8000 psi (552 bar)	12000 psi (828 bar)	16000 psi (1104 bar)	20000 psi (1380 bar)
S-218-200D	525	510	470	375	230	-
(200:1 ratio)	(8.60)	(8.36)	(7.70)	(6.15)	(3.77)	-

Sprague SM-3

High Pressure Air Operated Mini Pumps

The single acting air-driven SM-3 mini pump was designed for low volume and high pressure applications.

Benefits

Easier and Lower Cost Maintenance –

Use of plastics in air drive module, unique air valve and non bolted construction make for simple overhaul. The SM-3 has less components than competitive products. No lubrication required.

Water or Oil Options –

Pump can be supplied to suit oil applications or more demanding water based systems.

Better Value for Money –

Various air valve operating modes are supplied as standard and can be readily field configured.

Flexibility –

Manual operation option available so pump can be used as a back up to main pump or in low volume lab applications.

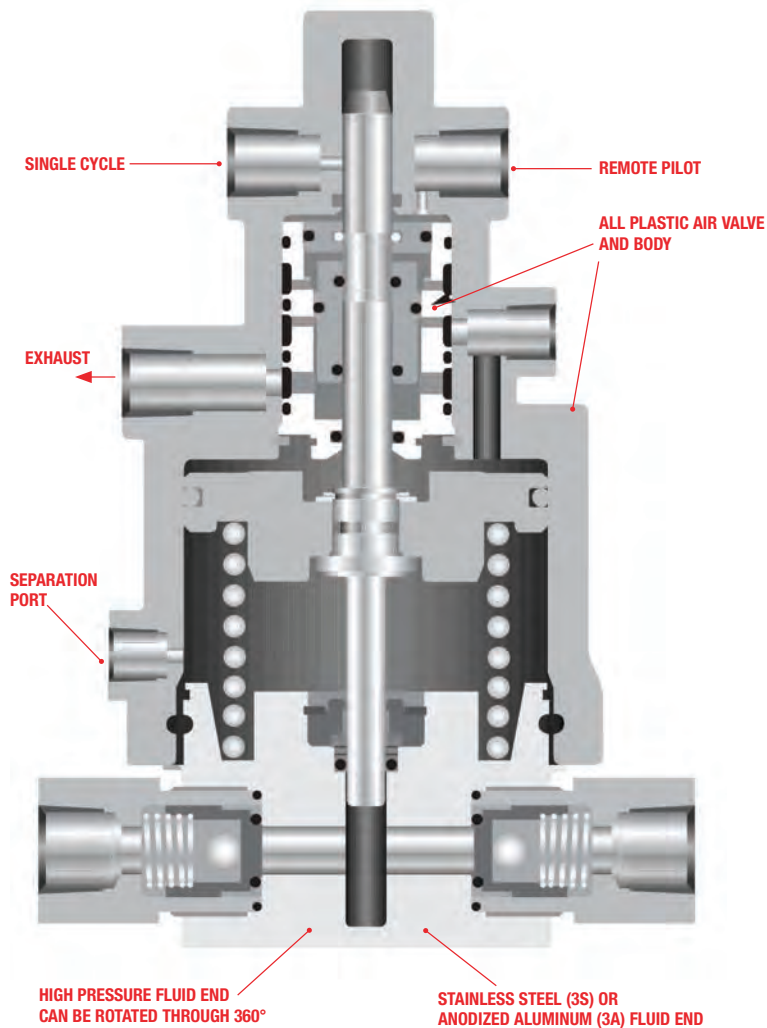

SM-3 Mini Pumps

How to Get the Best Performance

AIR FLOW dictates how fast the pump can cycle and hence flow rate depends on how much air is available. However as the pump pressure increases, the flow rate will decrease and the air consumption reduces to zero at stall pressure. Normal performance is based on maximum operating Air Supply of 15 SCFM @ 100 PSI.

AIR PRESSURE available produces a discharge pressure dependent on the RATIO of the pump.

2

Only need pressure - flow rate unimportant

Where a maximum pressure is required and the flow rate is unimportant then the available air pressure has to be sufficient for the selected ratio.

Air drive pressure x Actual Ratio = maximum discharge pressure.

Where a maximum flow at a specified pressure is required this “duty point” has to be within the constraints of available air flow and pressure.

Need pressure and flow

This needs to be plotted on the flow curves for the pump and should, if possible, be within the optimum operating region as shown above, which is within the operating region dictated by the min and max limits for air flow and air pressure.

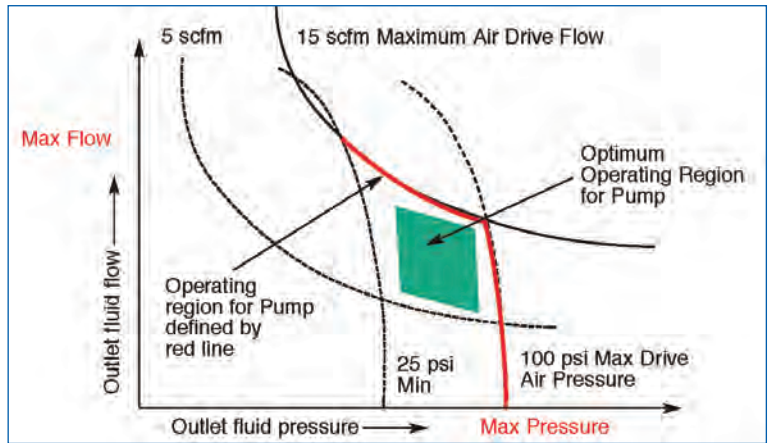

The pump performance is defined by a combination of outlet pressure and flow.

Pump Ratio Selection Chart

For the following pump models: SM-3A, SM-3S

Actual Ratio	Nominal Ratio	Nominal Output Pressure	Disp. Per Stroke Cu.In.	LIQUID DISCHARGE PRESSURE – PSI															
				0	100	200	350	500	1000	1500	2M	4M	6M	8M	10M	12M	15M	20M	
				CAPACITIES – CUBIC INCHES PER MINUTE APPROXIMATE															
5.75:1	5:1	500	1.050	550	330	275	180												
11.5:1	10:1	1000	0.527	476	350	200	180	150	10										
23:1	20:1	2000	0.263	305	280	210	160	110	75	60	15								
40.3:1	35:1	3500	0.150	158	140	120	100	90	60	50	40								
69:1	60:1	6000	0.085	98	90	80	75	60	31	25	22	17							
115:1	100:1	10000	0.053	58	55	53	50	48	40	30	21	16	14	10					
173:1	150:1	15000	0.035	39	38	37	36	35	28	25	20	12	11	9	7	6			
259:1	225:1	22500	0.023	24	23	22	21	20	18	17	16	9	8	7	6	5	4	3	

SM-3 Flow Performance

SM-3X-005 PUMP PERFORMANCE
(Based on Operating Air Supply of 12 - 15 SCFM)

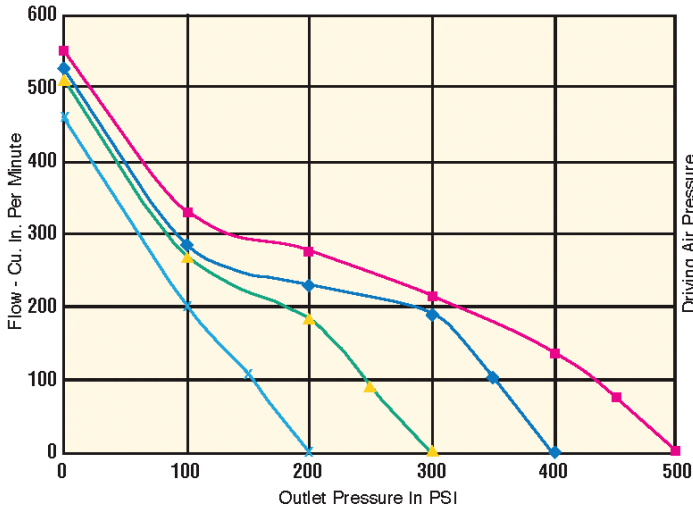

SM-3X-010 PUMP PERFORMANCE
(Based on Operating Air Supply of 12 - 15 SCFM)

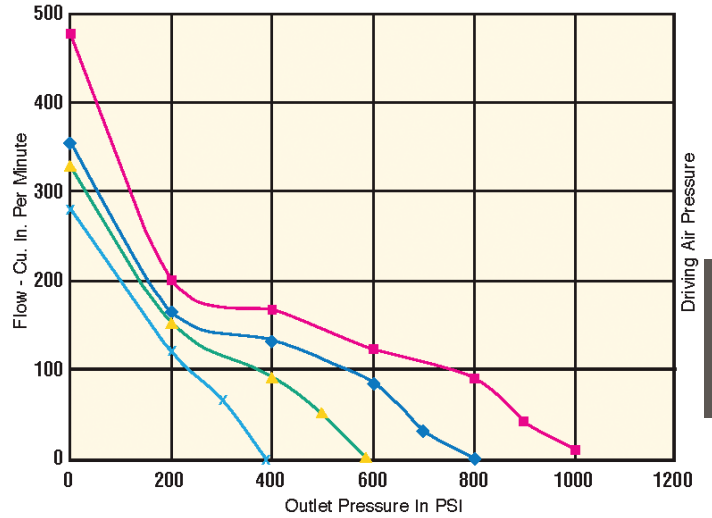

SM-3X-020 PUMP PERFORMANCE
(Based on Operating Air Supply of 12 - 15 SCFM)

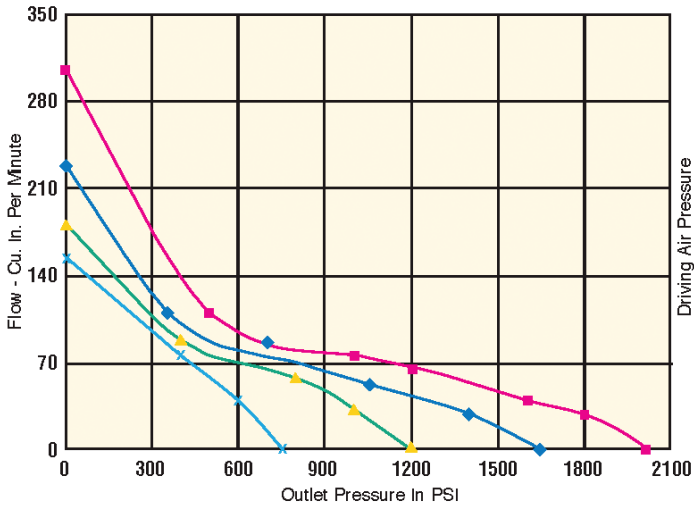

SM-3X-035 PUMP PERFORMANCE
(Based on Operating Air Supply of 12 - 15 SCFM)

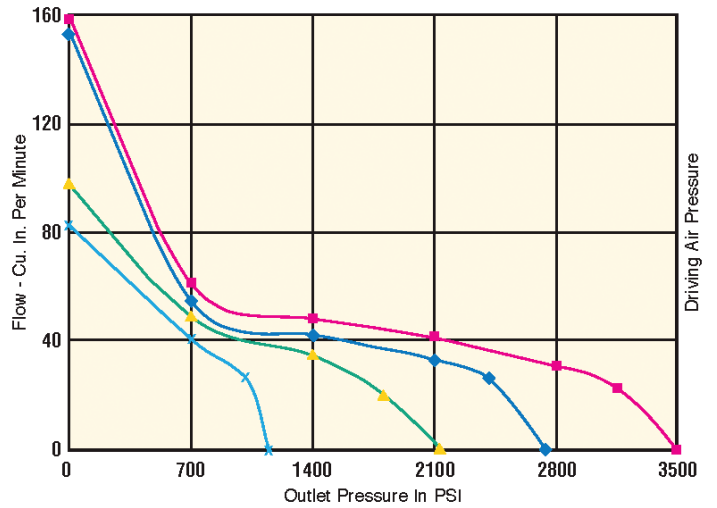

- Driving Air Pressures
- 100 psi
 - 80 psi
 - 60 psi
 - 40 psi

2

SM-3 Flow Performance

2

SM-3X-060 PUMP PERFORMANCE
(Based on Operating Air Supply of 12 - 15 SCFM)

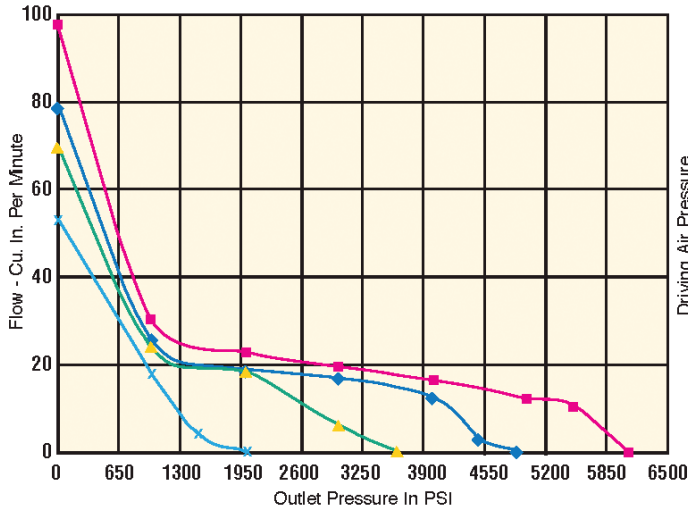

SM-3X-100 PUMP PERFORMANCE
(Based on Operating Air Supply of 12 - 15 SCFM)

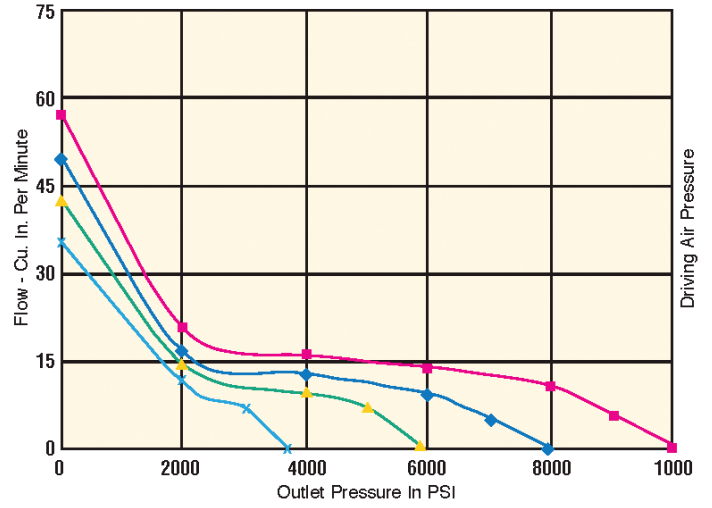

SM-3X-150 PUMP PERFORMANCE
(Based on Operating Air Supply of 12 - 15 SCFM)

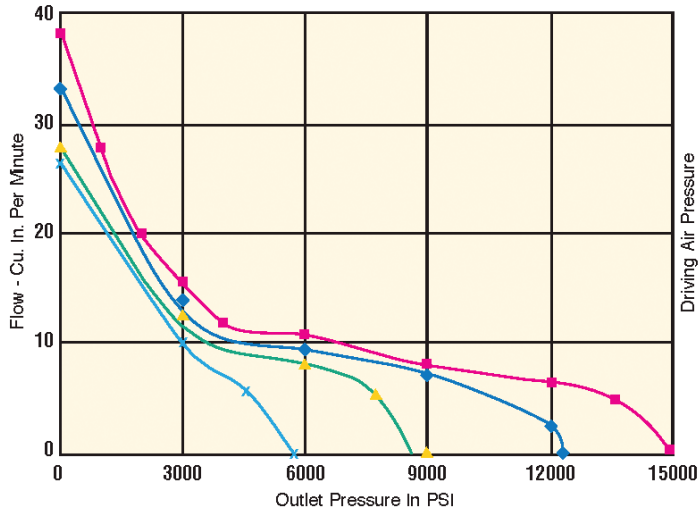

SM-3X-225 PUMP PERFORMANCE
(Based on Operating Air Supply of 12 - 15 SCFM)

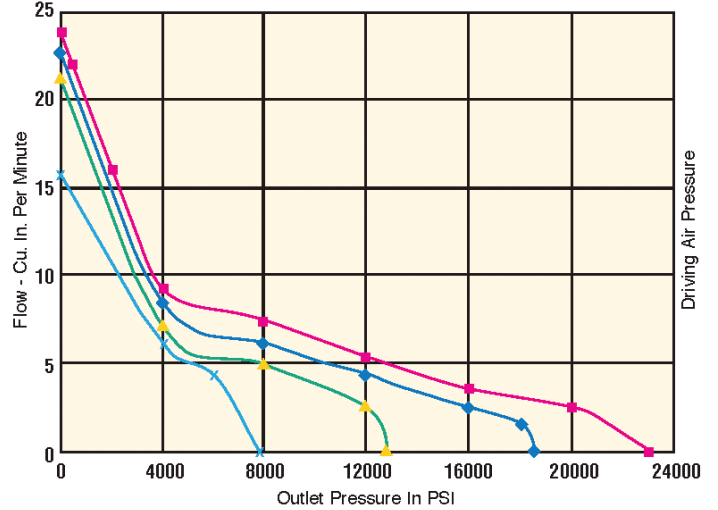

Driving Air Pressures

- 100 psi
- 80 psi
- 60 psi
- 40 psi

SM-3 Options

Materials –

SM-3 pumps are supplied with stainless steel (**SM-3S**) or Aluminium (**SM-3A**) fluid ends and all plastic air modules.

Anodized aluminium bodies are for oil and non-corrosive applications. SS bodies are for aqueous and most other fluids.

Ratio –

See pump rate selection chart on page 28.

Air and Fluid Ports –

SM-3 pumps are supplied with NPT as standard for air and fluid connections. However, pumps capable of pressures in excess of 10,000 psi have coned and threaded outlet fluid connections **HF4, 1/4 HP** in place of NPT as per the table below.

Seals –

UHMWPE with Nitrile is supplied as standard. Selection of the best seal package is based on fluid temperature and chemical compatibility. Contact your local distributor or HiP for required assistance.

Exhaust –

SM-3 pumps are supplied with a muffler/silencer as standard. When using non breathable gas to drive the pump, air pilot exhaust and main drive exhaust must be piped away to a safe area.

Separation–

An 1/8” threaded port is provided in the air cylinder body as standard. This section of the pump separates the air drive from the fluid section.

Air Control Options –

The SM-3 pumps are supplied with internal pilot as standard. Various control options can be configured at installation. The air valve is the heart of the pump and this feature provides the maximum flexibility in controlling how the pump operates and how the exhaust air is directed.

Remote Pilot (R) allows the customer to start and stop the pump by using a remote air pilot switch. In this mode the air pilot switch senses the pressure output from the pump and can be arranged to switch the pump on or off at preset high or low pressures. The customer supplies the remote air pilot switch. This feature is extremely useful for systems engineers where a specific pressure must be maintained.

Single Cycle Mode (S) is used where the pump is required to accurately discharge a given flow. The S configuration provides a control feature that when a pulse of air is supplied to the port the pump will travel one full cycle. The pulse rate can be set using standard air logic controls to govern the flow rate accurately. This feature is particularly useful in chemical injection applications.

Manual Operation (H) –

The SM-3 can be supplied with a hand lever for manual operation. This option allows the pump to be used as a back up to a main pump or in low volume lab applications.

ORDERING INFORMATION

Catalog Number	Pump Ratio
SM - 3A	- 005
Aluminum	- 010
SM- 3S	- 020
Stainless	- 035
	- 060
	- 100
	- 150*
	- 225*
	*(stainless steel only)

To order a standard stainless steel pump, specify ratio eg: SM-3S-10. To order a standard anodized aluminum pump, specify ratio eg: SM-3A-10.

To order options, simply add the option number(s) eg:

- SM-3A-10-H
- SM-3S-10-R
- SM-3S-35-02-H
- SM-3A-150-H

OPTIONS

PORTS	SEALS	CONTROLS
NPT – ratio's	UHMWPE/ NITRILE (STANDARD)	Internal Pilot Supply (STANDARD)
-005		
-010		
-020	- 02	- R
-035	PTFE/ NEOPRENE	Remote Pilot Supply (user configured)
-060		
(STANDARD)	- 03	
HF4 – ratio's	PTFE/VITON	- S
-100		Single Cycle (user configured)
- 150	- 04	
- 225	PTFE/EPR	- H
(STANDARD)		Manual Hand Lever
- 225*		

SM-3 Dimensional Data

2

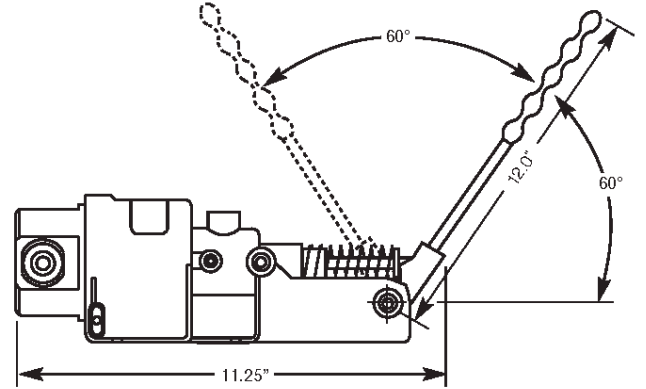
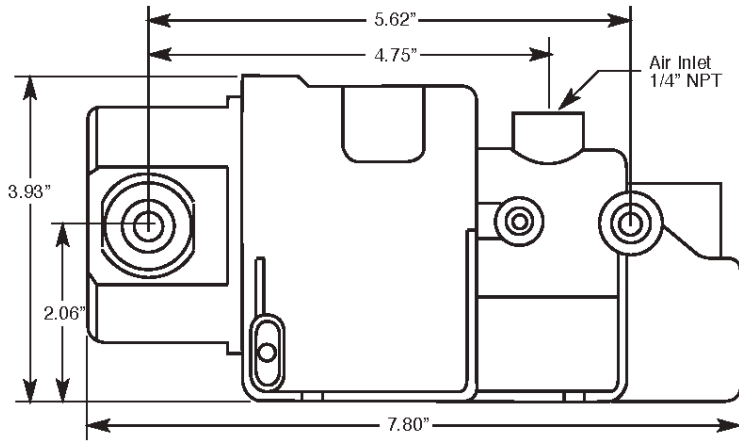

Hand Pump Option

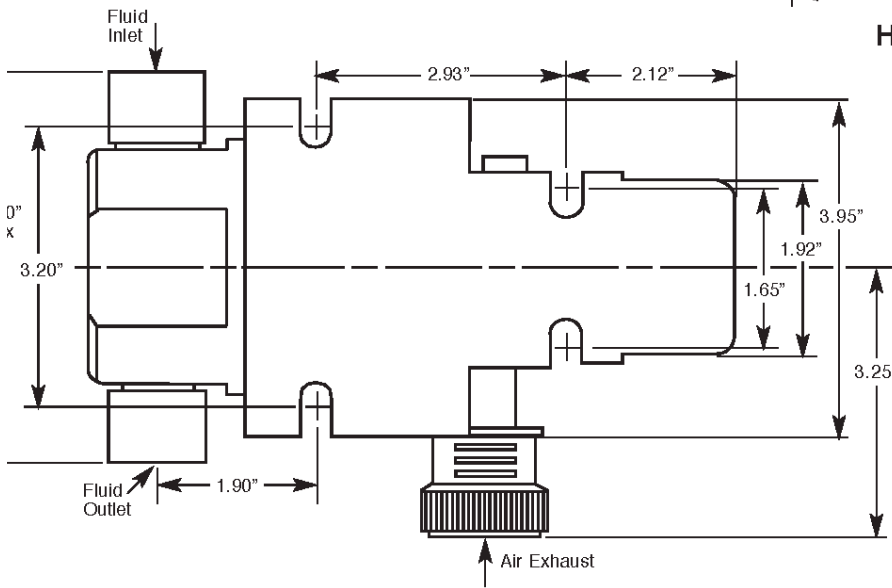

Bolt Hole Machining use
1/4" (6mm) Fasteners

- STD. ALUM. BODY 4.5 LBS.
- STD. ST. STL. BODY 6.75 LBS.
- HAND ALUM. BODY 5.75 LBS.
- HAND ST. STL. BODY 8.00 LBS.

Porting - Standard Pumps

Part No.	Fluid Inlet Port	Fluid Outlet Port B	Air Inlet Remote and Single Port
SM-3#-050	3/8" NPT	3/8" NPT	1/4" NPT
SM-3#-010	3/8" NPT	3/8" NPT	1/4" NPT
SM-3#-020	3/8" NPT	3/8" NPT	1/4" NPT
SM-3#-035	3/8" NPT	3/8" NPT	1/4" NPT
SM-3#-060	3/8" NPT	3/8" NPT	1/4" NPT
SM-3#-100	1/4" NPT	9/16"-18 NBS (1/4" HP)	1/4" NPT
SM-3#-150	1/4" NPT	9/16"-18 NBS (1/4" HP)	1/4" NPT
SM-3#-225	1/4" NPT	9/16"-18 NBS (1/4" HP)	1/4" NPT

Mounting Bolts - 1/4" or M6

Sprague PowerStar™ 4

Advanced Air Driven Pump System

Features

- A patented design
- One common air motor module for all eight ratios
- Easy conversion to separated (non-contaminating) configuration
- A double-ended unit that provides even higher flows
- Safe operation in hazardous environments
- Automatic shut-off at set pressure
- Stainless steel wetted parts
- Easy assembly and service for air motor and high pressure modules (field assembly requires careful alignment; (see Assembly & Operating Instructions)

Ideal Use for:

- Hydrostatic testing of pressure vessels using various liquids (avoid running the pump dry or sudden release of outlet pressure)
- Low volume, high pressure testing
- Low volume, liquid transfer (higher pressure capability than double diaphragm pumps)

Suitable for Most Water Applications

- Cleanliness and lubricity of liquid being pumped will affect pump seal life.
- A five-micron inlet filter is recommended.
- For applications that contain highly contaminated air and/or liquids, contact the Factory.



Single Ended



Double Ended

How the PowerStar™ 4 Pump Works

The PowerStar™ 4 pumps develop high output pressures by applying the principle of differential areas. The pump has a large area air piston (air driven at low 5 to 100 psi pressures). This air piston drives a small area liquid piston that pumps liquids to high pressures.

The liquid output pressure is determined by the ratio between the area of the air drive piston, the area of the liquid drive piston and the applied driving air pressure. The relationship of the area of the air piston to the liquid piston is referred to as the pump ratio which is indicated in the number following the air module number (P4).

Example: The P45 pump has a nominal ratio of 5 to 1 or 5 psi liquid pressure for each 1 psi of operating air pressure. In operation, the P45 pump using 100 psi of input air pressure could produce a maximum liquid output of 480 psi; 80 psi air - 370 psi output; 60 psi air - 270 psi output; and 40 psi air - 180 psi output. Output pressures will vary and be reduced by 5 to 10% through internal friction depending on the lubricity of the liquid.

By regulating the incoming air supply at the pressure regulator, the liquid output can be infinitely adjusted through the pump's pressure range.

2

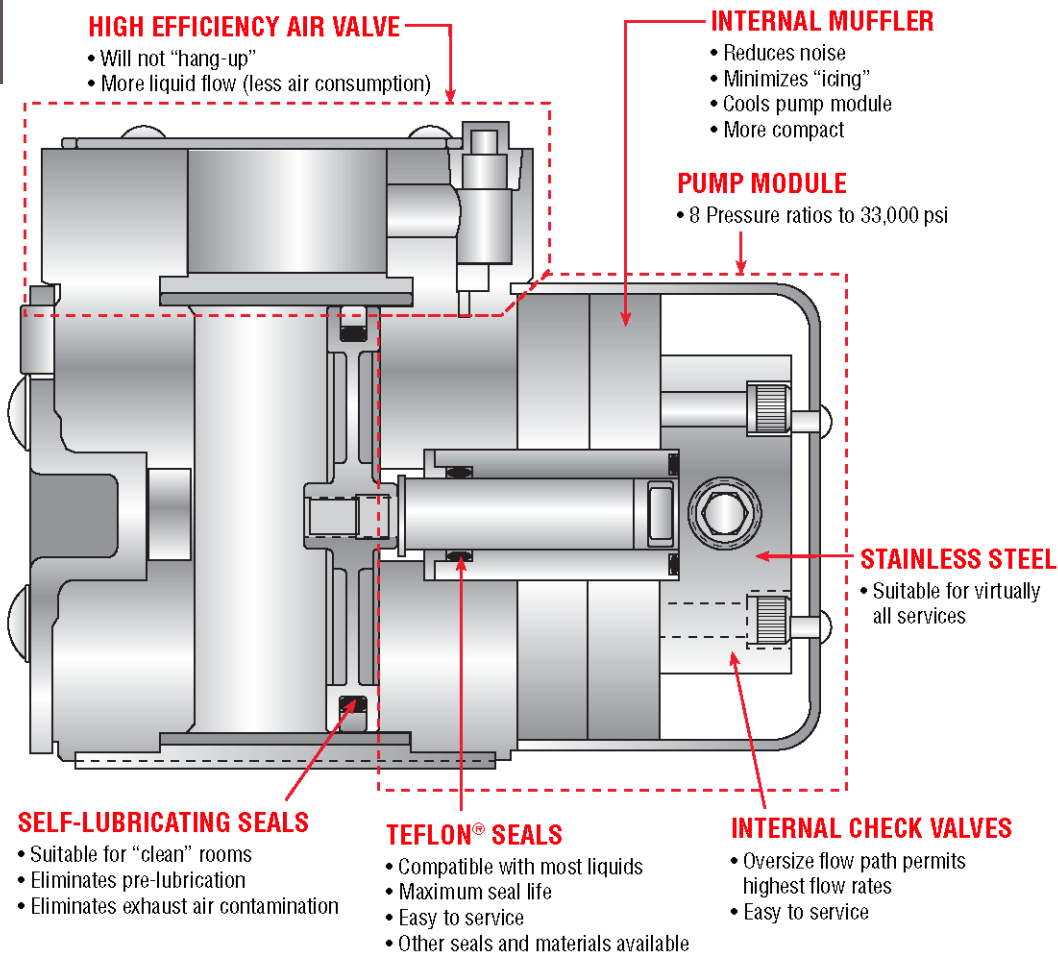

TEFLON is a registered trademark of the E. I. du Pont de Nemours & Co.

PowerStar™ 4 Performance

SAMPLE PERFORMANCE CHART

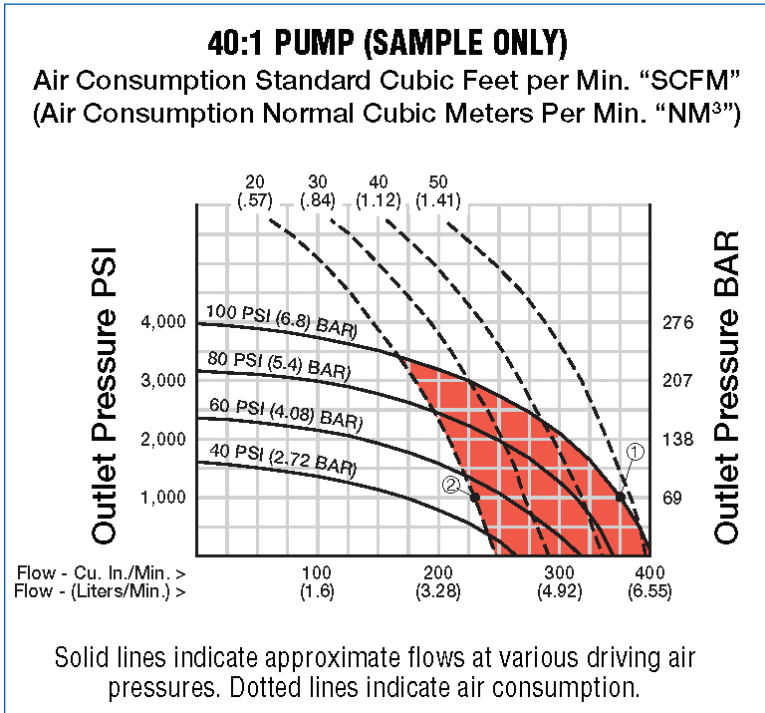

EXAMPLES:

- 1 With **100 PSI (6.8 BAR)** driving air, the pump will consume **50 SCFM (1.41 NM³/MIN)** at an operating pressure of **1,000 PSI (68 BAR)** and will produce an outlet flow of **358 Cu. In./Min. (5.9 LPM)**.
- 2 If the volume of compressed air is reduced to **20 SCFM (.57 NM³/MIN)**, the flow will be reduced to **225 Cu. In./Min. (15.3 Liters)**. Shaded area indicated flow reduction.

NOTES:

- Most air compressors will produce **4 to 5 SCFM** of compressed air per horsepower at **100 PSI**.
- All air driven pumps will operate on low air volumes as long as the supply of air is sufficient to operate the air selector valve.
- Performance charts are based upon air supply stated, pumping oil (Mil-H-5606) with flooded suction.

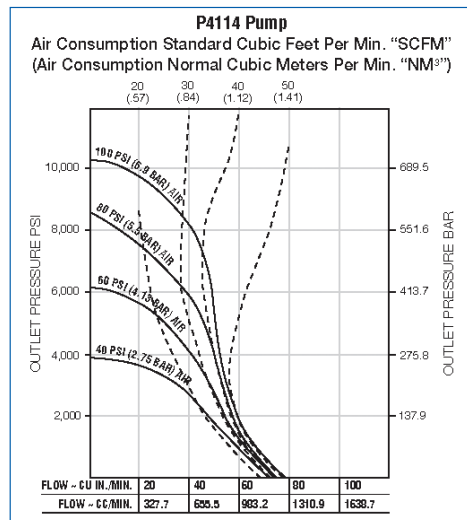
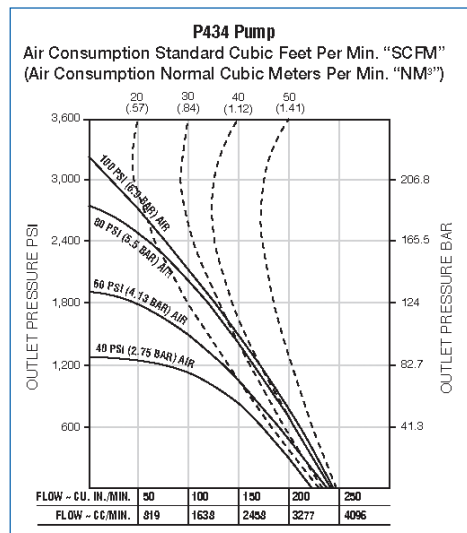
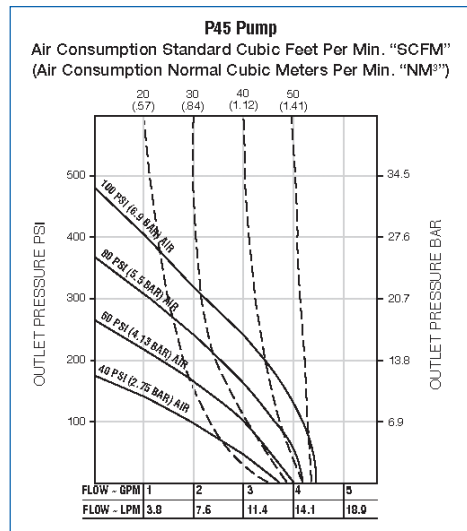

**"Typical" or "Nominal" Performance,
 Double Ended Pumps = 1.6% of
 Single Pump Flow.**

PowerStar™ 4 Performance

2

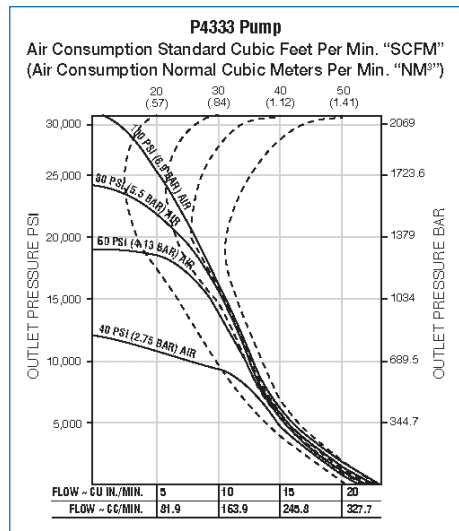
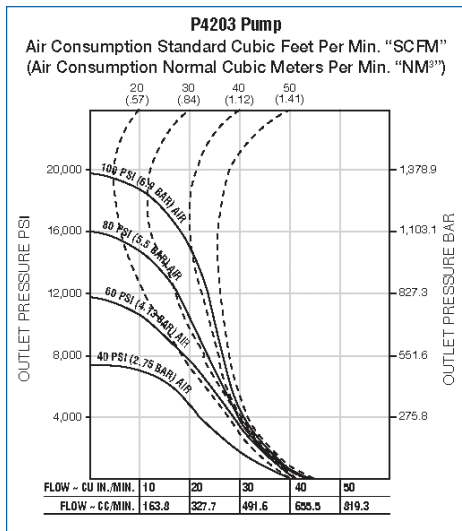
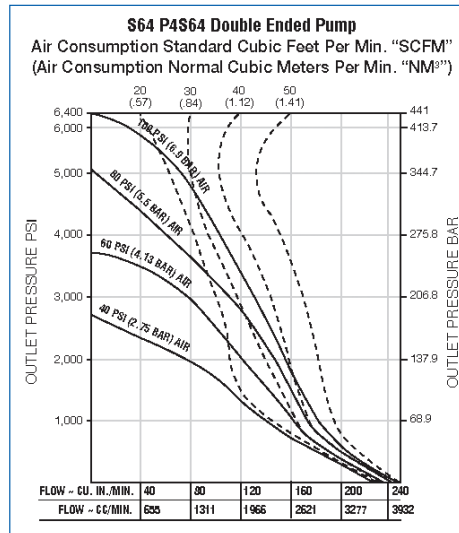
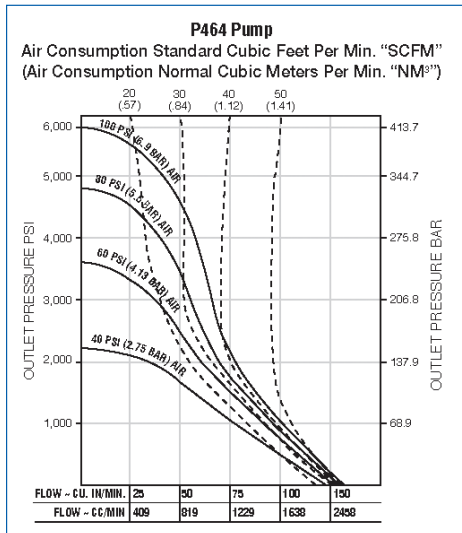
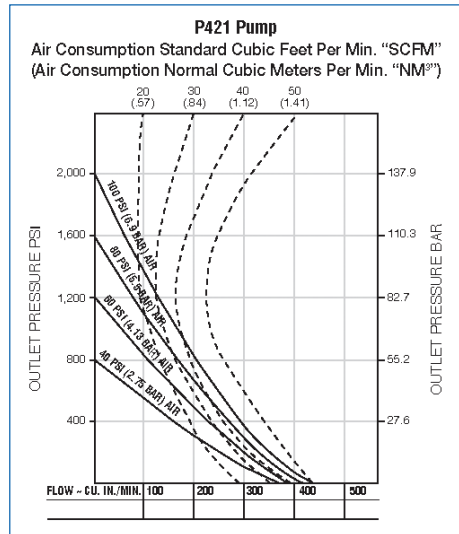
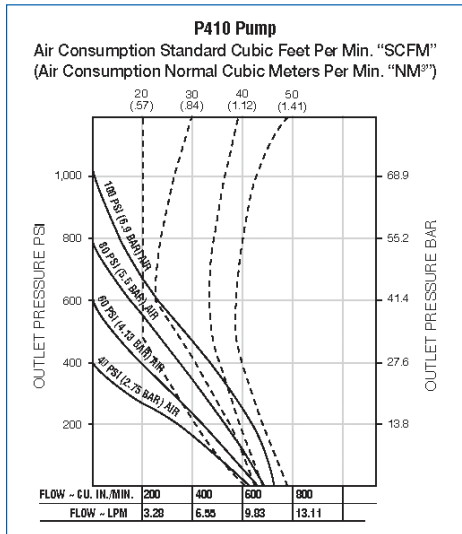

"Typical" or "Nominal" Performance, Double Ended Pumps = 1.6% of Single Pump Flow.

PowerStar™ 4 Part Identification

COMPLETE UNIT EXAMPLES

(USING A 64:1 RATIO):

- Standard 64:1 ratio pump P464
- Separated 64:1 ratio pump P4S64
- Double ended 64:1 ratio pump S64P4S64
- Double ended 64:1 ratio pump
w/ air controls S64P4S64C
- Double ended 64:1 ratio pump w/ air
and high pressure controls S64P4S64CP

	Air Module P4	Liquid Module 4F64	Sep Kit 4SK64	Air Controls 4ACKIT	Pressure Controls P
Air Motor Module P4	1				
Liquid Pump Module 4F64		1			
Single Air & Liquid Module P464	1	1			
Single Separated P4S64	1	1	1		
Double Ended S64P4S64	1	2	2		
Double Ended w/ Air S64PS64C	1	2	2	1	
Double Ended w/ Air & Pressure Controls S64P4S64CP	1	2	2	1	1

How to Order

To order a hydraulic pump, the ratio of the pump must be selected.

Define the liquid pressure and flow requirements for the application as well as the available air pressure and volume; then refer to the Pump Performance graphs on pages 35 & 36.

From the chart, select a pump that exceeds the requirements. Drive air may be throttled if flow must be reduced.

Use this pump liquid module ratio number and add it to the end of the pump air motor module number. **Example:** P45.

Nominal liquid module displacements are as follows:

- 5:1 ⇒ 2.4 cu in
- 10:1 ⇒ 1.2 cu in
- 21:1 ⇒ .6 cu in
- 34:1 ⇒ .37 cu in
- 64:1 ⇒ .2 cu in
- 114:1 ⇒ .11 cu in
- 203:1 ⇒ .06 cu in
- 333:1 ⇒ .04 cu in

PUMP NUMBERING SYSTEM

Typical Models

Model Number

- Standard 64:1 Ratio Pump P464
- w/ separator kit P4S64
- w/ air controls P464C
- w/ pressure & air controls P464CP
- Double ended
64:1 Ratio Pump* S64P4S64

* Double ended pumps require separation on both sides

Nitrile is the standard elastomer. The pumps can be furnished with other o-rings: Viton, EPR, Neoprene.

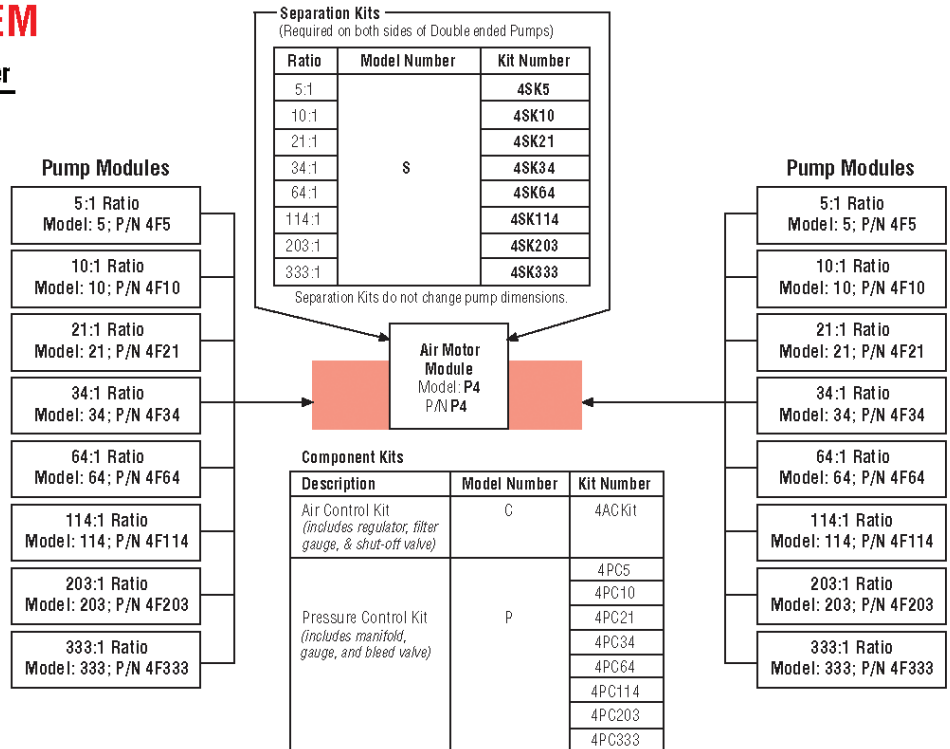

PowerStar™ 4 Dimensions, Weights and Porting

Single Ended

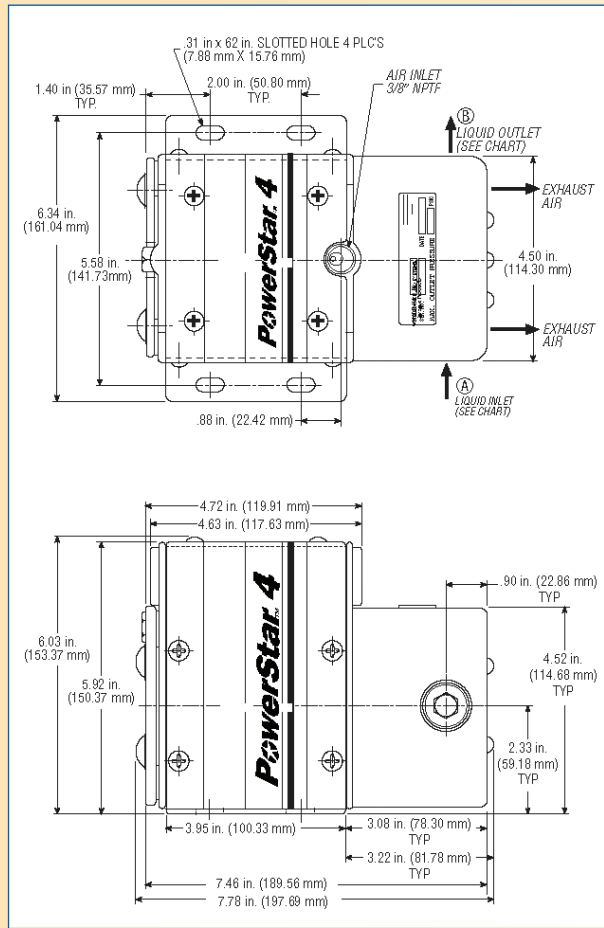

Double Ended

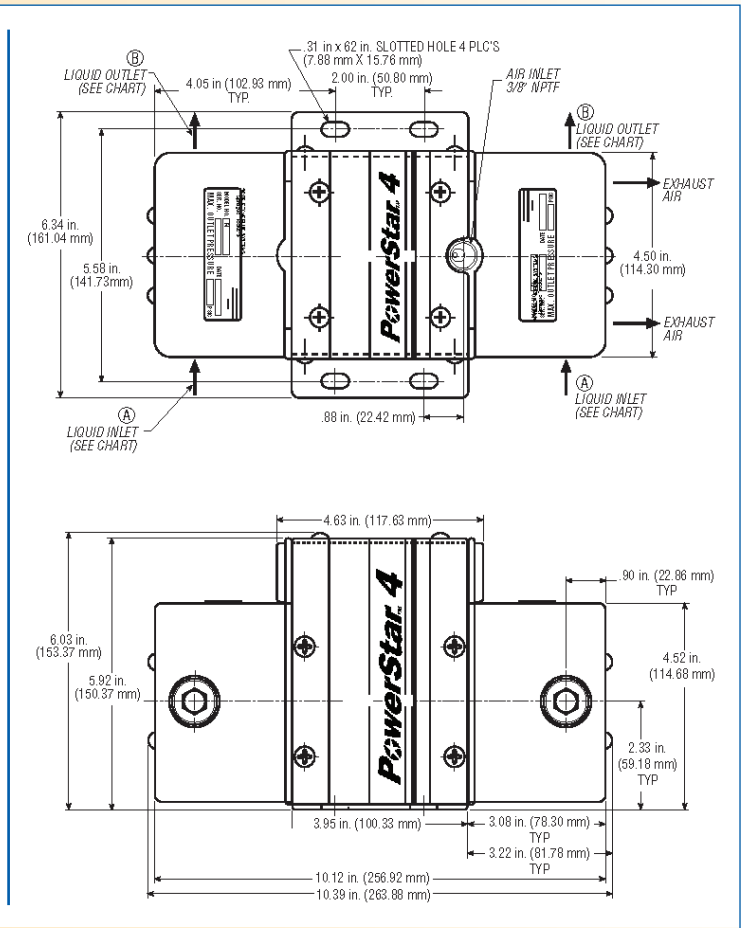

NOTE: Double ended units, fully plumbed, available upon request.

Pump Model	Inlet Port Liquid	Outlet Port Liquid	Inlet Port Air	Approximate Shipping Weight
P45	3/4" NPTF	1/2" NPTF	3/8" NPTF	16 lbs (7.26 Kg)
P410	3/4" NPTF	1/2" NPTF	3/8" NPTF	16 lbs (7.26 Kg)
P421	1/2" NPTF	3/8" NPTF	3/8" NPTF	16 lbs (7.26 Kg)
P434	1/2" NPTF	3/8" NPTF	3/8" NPTF	16 lbs (7.26 Kg)
P464	1/2" NPTF	3/8" NPTF	3/8" NPTF	16 lbs (7.26 Kg)
P4114	3/8" NPTF	9/16-18 NBS	3/8" NPTF	16 lbs (7.26 Kg)
P4203	3/8" NPTF	9/16-18 NBS	3/8" NPTF	16 lbs (7.26 Kg)
P4333	3/8" NPTF	9/16-18 NBS	3/8" NPTF	16 lbs (7.26 Kg)
Double Ended	Same	Same	Same	21 lbs (9.53 Kg)

High Pressure Hand Pump

JB Series Hand Pump

94301-()

This single-acting, piston type hand pump is ideal for hydrostatic testing and other industrial applications that require low volumes at high pressures.

The pump's stainless steel liquid body assembly (wetted section) is identical to and interchangeable with the liquid body assembly in the S-216-J-() standard pump, so the hand pump will service water, oil and most corrosive chemicals.

Directional control of the liquid through the pump is maintained through the inlet and outlet soft seat, zero leakage, check valves.

The pump is seven inches high from its base to the top of the pumping mechanism. The handle extends twenty-four inches and is furnished with a rubber grip.

The pump has two threaded mounting holes provided on the underside of the liquid body. The -35, -60, -100 and -101 pumps may be installed below or no more than two feet above the liquid source. The -125, -150, -200 and -300 pumps must be installed with the pumpinlet below the liquid source.

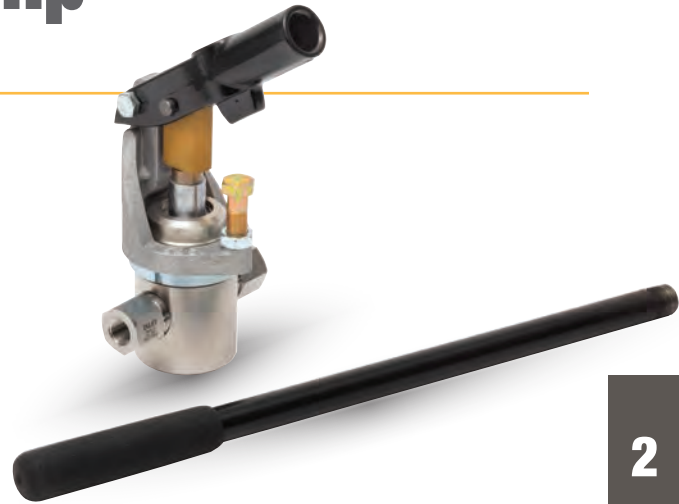

2

Nominal Dimensions and Clearances

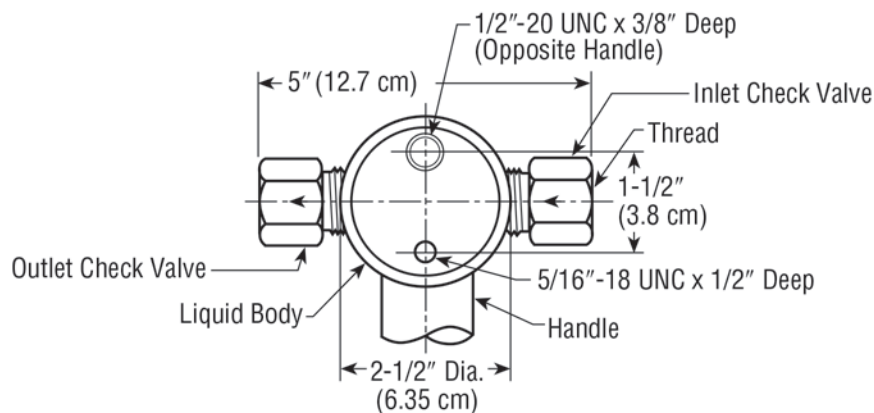

Mounting Dimension – Bottom View

Part No.	Pump Output with 75 lbs. Handle Load	Liquid Inlet	Liquid Outlet
94301-035	2220 psi	NFC	NFC
94301-060	3020 psi	NFC	NFC
94301-100	4350 psi	NFC	NFC
94301-101	4750 psi	NFC	NFC
94301-125	5390 psi	NFB	NFB
94301-150	6800 psi	NFB	NFB
94301-200	12000 psi	NFB	HF4
94301-300	17400 psi	NFB	HF4

Portable Pump Reservoir

JR Series Pump/Reservoir

S-216-JNR-() Pump/Reservoir Non-lubricated

This pump assembly combines the S-216-JN standard pump (non-lubricated air type) with a one-gallon (3.8 liters) steel reservoir. No additional contaminants are exhausted from the pump. Readily adaptable to portable power pack use. Also suitable for stationary use to provide hydraulic power for production machinery or for hydrostatic testing. This unit is not available in 150:1, 200:1 or 300:1 ratios.

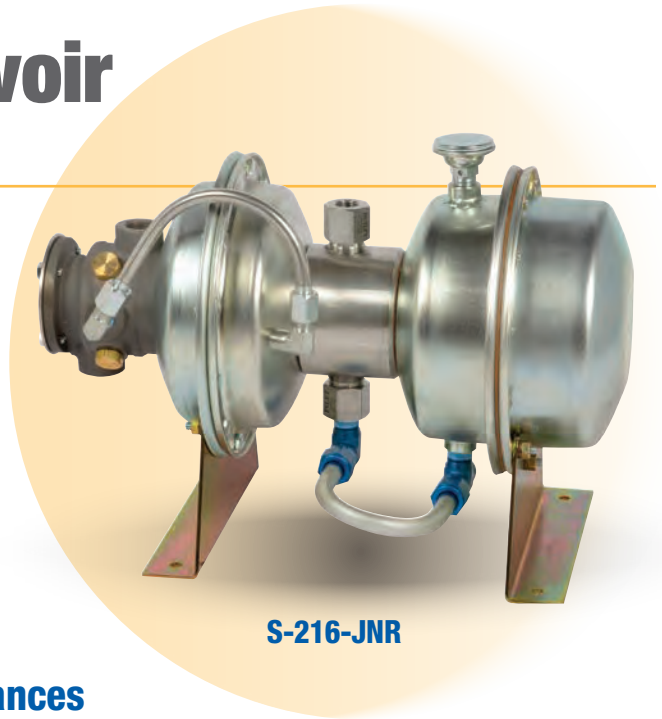

S-216-JNR

2

S-216-JNR Nominal Dimensions and Clearances

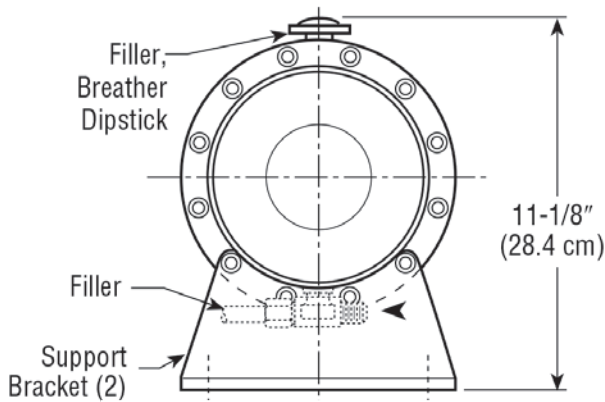

Reservoir End View

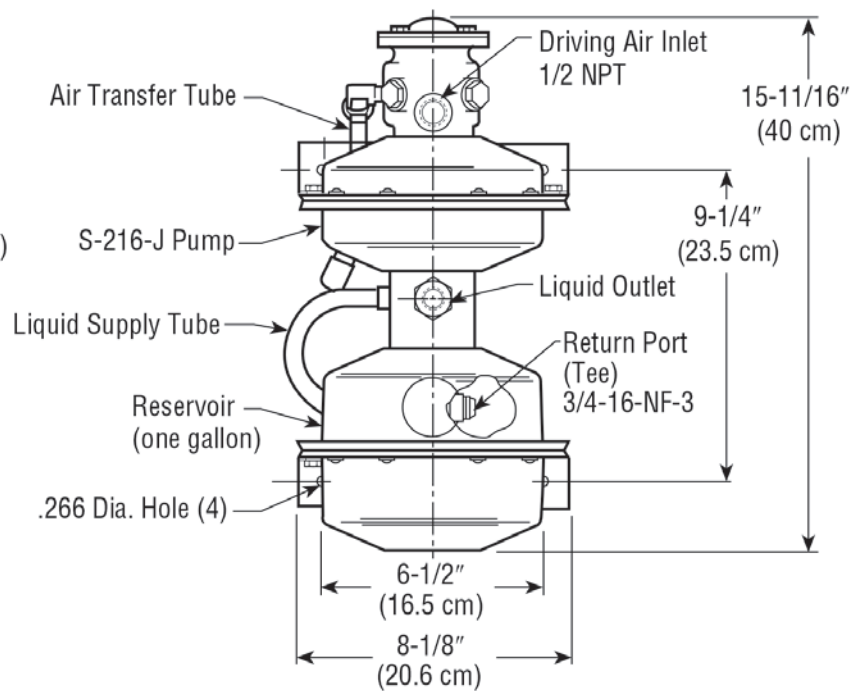

View Looking Down at Pump/Reservoir

Portable Pump Reservoir - JR Series

Model No.	Ref. No	Maximum Output - See Note		Port Threads			Actual Weight		Shipping Weight	
				Driving Air	Liquid		lbs.-oz.	kg	lbs.-oz.	kg
		psi	bar		Inlet	Outlet				
S-216-JNR-10	89842-1	1025	71	1/2 NPT	3/8 NPT	3/8 NPT	24-4	11.0	27-4	12
S-216-JNR-20	89842-2	1910	132	1/2 NPT	3/8 NPT	3/8 NPT	22-8	10.2	25-8	11.6
S-216-JNR-30	89842-3	3200	221	1/2 NPT	3/8 NPT	3/8 NPT	22-8	10.2	25-8	11.6
S-216-JBNR-35	94198-035	4760	328	1/2 NPT	3/8 NPT	3/8 NPT	20-8	9.3	23-8	10.7
S-216-JBNR-60	94198-060	6330	436	1/2 NPT	3/8 NPT	3/8 NPT	20-8	9.3	23-8	10.7
S-216-JBNR-100	94198-101	9100	627	1/2 NPT	3/8 NPT	3/8 NPT	20-8	20-8	23-8	10.7
S-216-JBNR-101	94198-101	10000	690	1/2 NPT	3/8 NPT	3/8 NPT	20-8	20-8	23-8	10.7
S-216-JBNR-125	94198-125	12400	855	1/2 NPT	1/4 NPT	9/16-18 NBS	12-8	5.7	15	6.8
S-216-JBNR-150	94198-150	16200	1117	1/2 NPT	1/4 NPT	9/16-18 NBS	20-8	9.3	23-8	10.7
S-216-JBNR-200	94198-200	24900	1717	1/2 NPT	1/4 NPT	9/16-18 NBS	20-8	9.3	23-8	10.7
S-216-JBNR-300	94198-300	36500	2517	1/2 NPT	1/4 NPT	9/16-18 NBS	20-8	9.3	23-8	10.7

NOTE: Pump maximum output pressure is based on 100 psi (6.9 bar) driving air pressure.

