



High Pressure Equipment

Low Pressure Valves, Fittings and Tubing

Taper Seal -10,000 and 15,000 psi service

High Pressure Equipment Company has developed the Taper Seal line of products to assure safe and easy plumbing through 15,000 psi. These needle valves, fittings, line filters, check valves, safety heads, rupture discs and tubing are engineered and manufactured to the highest standards of repeatable quality. The reliable performance of these products has made HiP one of the world's leading suppliers of elevated pressure components.

Taper Seal components use a compression type tubing connection that requires no special tooling for tubing preparation. Taper Seal valves are available for $\frac{1}{16}$ ", $\frac{1}{8}$ ", $\frac{1}{4}$ ", and $\frac{3}{8}$ " O.D. tubing and five patterns to satisfy widely varying requirements. A line of fittings is available to facilitate adapting to NPT, Medium or High Pressure pipe systems.

2



Index

Valves	10-11
Fittings	12
Bulkhead Couplings & Caps	13
Line Filters & Check Valves	14
Safety Heads	15
Rupture Discs	16
Tubing	16
Connection Details	17
Assembly Procedure	18

Taper Seal Needle Valves

10,000 and 15,000 psi service

Compression type tubing connections for $\frac{1}{16}$ " , $\frac{1}{8}$ " , $\frac{1}{4}$ " , and $\frac{3}{8}$ " O.D. tubing. Requires no special tooling for tubing preparation (simply cut off, deburr, and insert tubing into connection). Connection details are shown on page 17.

2

Non-rotating slotted stems are standard on AF4 and AF6 for on-off service and ensure long life on valve seats. Regulating tip stems are available at no additional cost, add - REG to the catalog number.

Glands and sleeves are supplied with each valve unless otherwise requested (glands and sleeves shown on pages 12 and 17).

Materials include high tensile type 316 stainless steel for the valve body and hardened 17-4PH stainless steel lower section stem.

Packing is Teflon (450°F) standard, with optional Viton (350°F), BUNA-N (200°F) or Grafoil (650°F) available at no additional cost.

Air operators for remote control operation are available for all valves. (Refer to Air Operator section of catalog for additional data).

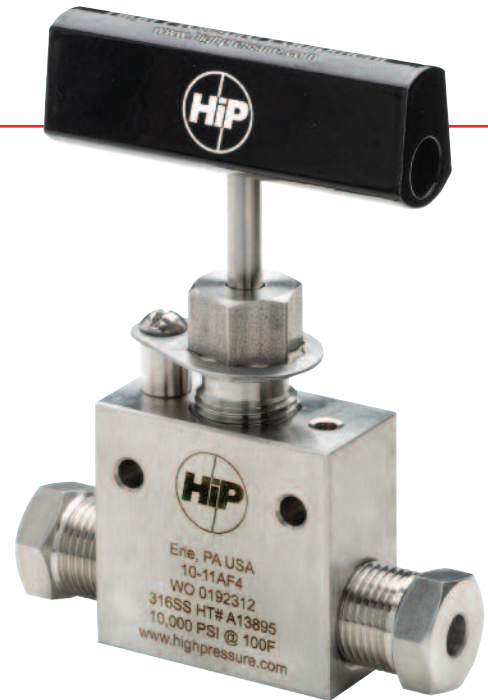

Valve Features

- Non-rotating slotted stem design (standard for AF4 and AF6)
- Packing below stem threads
- Type 316 ss high tensile bodies
- Positive gland lock device
- No stem adjustment needed
- Black T-handles or choice of 4 colors
- Tube sizes $\frac{1}{16}$ " through $\frac{3}{8}$ "

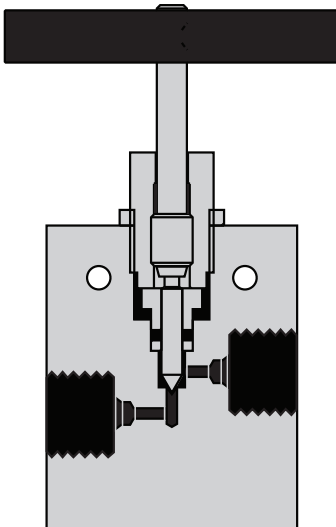

AF1 ($\frac{1}{16}$ ") and AF2 ($\frac{1}{8}$ ")
15,000 psi

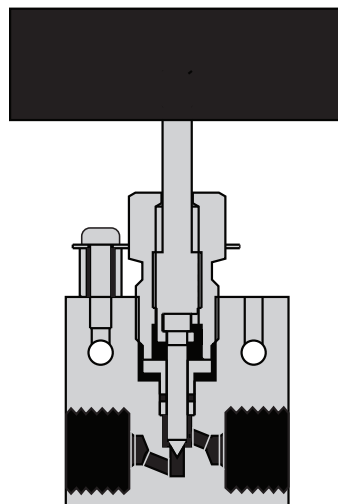

AF4 ($\frac{1}{4}$ ") and AF6 ($\frac{3}{8}$ ")
10,000 psi

Two Way Straight Valves

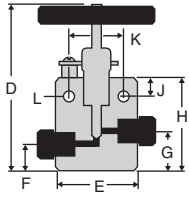

Tubing	Catalog No.	psi	Conn.	Orifice	Cv	D	E	F	G	H	J	K	L	Thickness
1/16" O.D.	15-11AF1	15,000	AF1	0.052"	0.03	2 1/2"	1 1/8"	1/4"	13/32"	1 1/8"	5/16"	3/4"	9/64"	1/2"
1/8" O.D.	15-11AF2	15,000	AF2	1/16"	0.05	3 1/8"	1 1/2"	1 1/16"	15/16"	1 13/16"	5/16"	7/8"	9/64"	3/4"
1/4" O.D.	10-11AF4	10,000	AF4	1/8"	0.15	4 5/8"	2"	1/2"	1 1/2"	1 7/8"	1/2"	1 3/8"	7/32"	1"
3/8" O.D.	10-11AF6	10,000	AF6	1/8"	0.15	4 5/8"	2"	1/2"	1 1/2"	1 7/8"	1/2"	1 3/8"	7/32"	1"

Two Way Angle Valves

2

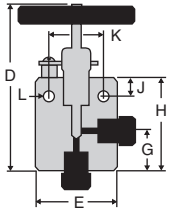

Tubing	Catalog No.	psi	Conn.	Orifice	Cv	D	E	F	G	H	J	K	L	Thickness
1/16" O.D.	15-12AF1	15,000	AF1	0.052"	0.045	2 3/8"	1 1/8"	—	2 1/32"	1 3/8"	5/16"	3/4"	9/64"	1/2"
1/8" O.D.	15-12AF2	15,000	AF2	1/16"	0.075	3 1/8"	1 1/2"	—	15/16"	1 13/16"	5/16"	7/8"	9/64"	3/4"
1/4" O.D.	10-12AF4	10,000	AF4	1/8"	0.225	5 3/16"	2"	—	1 1/16"	2 7/16"	1/2"	1 3/8"	7/32"	1"
3/8" O.D.	10-12AF6	10,000	AF6	1/8"	0.225	5 3/16"	2"	—	1 1/16"	2 7/16"	1/2"	1 3/8"	7/32"	1"

Three Way Valves / Two Pressure Connections

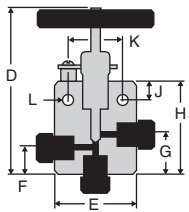

Tubing	Catalog No.	psi	Connection	Orifice	D	E	F	G	H	J	K	L	Thickness
1/16" O.D.	15-13AF1	15,000	AF1	0.052"	2 3/4"	1 1/8"	1/2"	2 1/32"	1 3/8"	5/16"	3/4"	9/64"	1/2"
1/8" O.D.	15-13AF2	15,000	AF2	1/16"	3 1/8"	1 1/2"	1 1/16"	15/16"	1 13/16"	5/16"	7/8"	9/64"	3/4"
1/4" O.D.	10-13AF4	10,000	AF4	1/8"	5 3/16"	2"	1/2"	1 1/16"	2 7/16"	1/2"	1 3/8"	7/32"	1"
3/8" O.D.	10-13AF6	10,000	AF6	1/8"	5 3/16"	2"	1/2"	1 1/16"	2 7/16"	1/2"	1 3/8"	7/32"	1"

Three Way Valves / One Pressure Connection

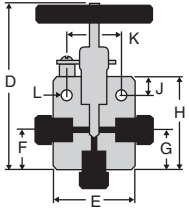

Tubing	Catalog No.	psi	Connection	Orifice	D	E	F	G	H	J	K	L	Thickness
1/16" O.D.	15-14AF1	15,000	AF1	0.052"	2 3/4"	1 1/8"	2 1/32"	2 1/32"	1 3/8"	5/16"	3/4"	9/64"	1/2"
1/8" O.D.	15-14AF2	15,000	AF2	1/16"	3 1/8"	1 1/2"	15/16"	15/16"	1 13/16"	5/16"	7/8"	9/64"	3/4"
1/4" O.D.	10-14AF4	10,000	AF4	1/8"	5 3/16"	2"	1 1/16"	1 1/16"	2 7/16"	1/2"	1 3/8"	7/32"	1"
3/8" O.D.	10-14AF6	10,000	AF6	1/8"	5 3/16"	2"	1 1/16"	1 1/16"	2 7/16"	1/2"	1 3/8"	7/32"	1"

Three Way / Two Stem Connection Valves

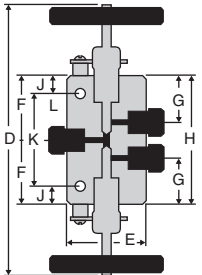

Tubing	Catalog No.	psi	Connection	Orifice	D	E	F	G	H	J	K	L	Thickness
1/16" O.D.	15-15AF1	15,000	AF1	0.052"	4 3/4"	1 1/8"	1"	23/32"	2"	5/16"	1 3/8"	9/64"	1/2"
1/8" O.D.	15-15AF2	15,000	AF2	1/16"	5"	1 1/2"	1 1/4"	7/8"	2 1/2"	5/16"	1 7/8"	9/64"	3/4"
1/4" O.D.	10-15AF4	10,000	AF4	1/8"	8 7/8"	2"	1 11/16"	1 3/16"	3 3/8"	1/2"	2 3/8"	7/32"	1"
3/8" O.D.	10-15AF6	10,000	AF6	1/8"	8 7/8"	2"	1 11/16"	1 3/16"	3 3/8"	1/2"	2 3/8"	7/32"	1"

Replaceable Seat Valve

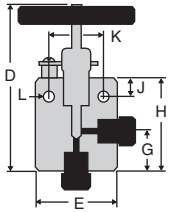

Tubing	Catalog No.	psi	Connection	Orifice	D	E	F	G	H	J	K	L	Thickness
1/4" O.D.	10-12AF4-R	10,000	AF4	1/8"	6 1/8"	2"	—	1 3/8"	2 7/16"	1/2"	1 7/8"	7/32"	1"
3/8" O.D.	10-12AF6-R	10,000	AF6	1/8"	6 1/8"	2"	—	1 1/8"	2 7/16"	1/2"	1 7/8"	7/32"	1"

Taper Seal Valves

Glands/Sleeves/Plugs/Elbows/Tees/Crosses

A complete range of elbows, tees, and crosses is available for all of the tubing connection sizes. Material is high tensile 316 stainless steel. Standard tubing glands and sleeves are furnished unless otherwise specified.

2

Connection Components

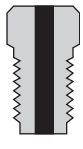
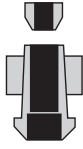
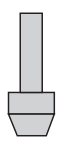
Catalog No.	Tube Size	Gland	Catalog No.	Tube Size	Sleeve	Catalog No.	Tube Size	Plug
15-2AM1	1/16"		15-2A1	1/16"		15-7AM1	1/16"	
15-2AM2	1/8"		15-2A2	1/8"		15-7AM2	1/8"	
10-2AM4	1/4"		10-2A4	1/4"		10-7AM4	1/4"	
10-2AM6	3/8"		10-2A6	3/8"		10-7AM6	3/8"	

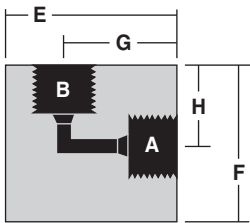

Taper Seal Elbows

Catalog No.	Pressure Rating psi	Connections	A-B	E	F	G	H	Thickness
15-22AF1	15,000	1/16" O.D. TUBE	AF1	3/4"	3/4"	9/16"	9/16"	3/8"
15-22AF2	15,000	1/8" O.D. TUBE	AF2	1 1/8"	1 1/8"	3/4"	3/4"	3/4"
10-22AF4	10,000	1/4" O.D. TUBE	AF4	1 1/2"	1 1/2"	1"	1"	1"
10-22AF6	10,000	3/8" O.D. TUBE	AF6	1 1/2"	1 1/2"	1"	1"	1"

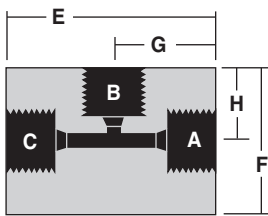

Taper Seal Tees

Catalog No.	Pressure Rating psi	Connections	A-B-C	E	F	G	H	Thickness
15-23AF1	15,000	1/16" O.D. TUBE	AF1	1"	3/4"	1/2"	9/16"	3/8"
15-23AF2	15,000	1/8" O.D. TUBE	AF2	1 1/2"	1 1/8"	3/4"	3/4"	3/4"
10-23AF4	10,000	1/4" O.D. TUBE	AF4	2"	1 1/2"	1"	1"	1"
10-23AF6	10,000	3/8" O.D. TUBE	AF6	2"	1 1/2"	1"	1"	1"

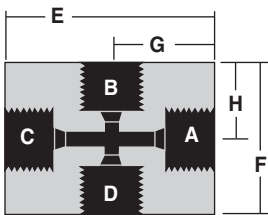

Taper Seal Crosses

Catalog No.	Pressure Rating psi	Connections	A-B-C-D	E	F	G	H	Thickness
15-24AF1	15,000	1/16" O.D. TUBE	AF1	1"	1"	1/2"	1/2"	3/8"
15-24AF2	15,000	1/8" O.D. TUBE	AF2	1 1/2"	1 1/2"	3/4"	3/4"	3/4"
10-24AF4	10,000	1/4" O.D. TUBE	AF4	2"	2"	1"	1"	1"
10-24AF6	10,000	3/8" O.D. TUBE	AF6	2"	2"	1"	1"	1"

Bulkhead Couplings

Bulkhead couplings are designed specifically for passing a tubing connection through a panel or steel barricade. These couplings include a locknut as shown. Material is high tensile 316 stainless steel. Standard tubing collars and glands are included unless otherwise specified.

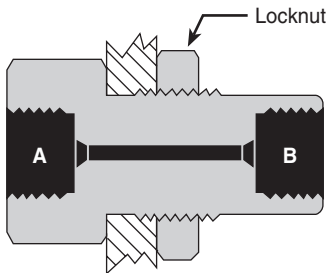

Catalog No.	Tubing	psi	Connections	Orifice	Length	Hex	Hole Diameter	Max. Panel Thickness
15-21AF1-B	1/16"	15,000	AF1	0.052"	1 1/8"	3/4"	9/16"	5/16"
15-21AF2-B	1/8"	15,000	AF2	5/64"	1 3/8"	1"	13/16"	3/8"
10-21AF4-B	1/4"	10,000	AF4	1/8"	2 1/8"	1 3/8"	1 1/8"	5/8"
10-21AF6-B	3/8"	10,000	AF6	1/4"	2 1/8"	1 3/8"	1 1/8"	5/8"

2

Caps

Tubing end caps are offered for use in sealing off tubing ends either for temporary use or permanent use, such as on small volume reservoirs. Standard material is high tensile 316 stainless steel. Standard tubing collars and glands are provided unless otherwise specified.

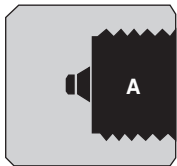

Catalog No.	Tubing	psi	A	Length	Hex
15-21AF1-C	1/16"	15,000	AF1	0.052"	1 1/8"
15-21AF2-C	1/8"	15,000	AF2	5/64"	1 3/8"
10-21AF4-C	1/4"	10,000	AF4	1/8"	2 1/8"
10-21AF6-C	3/8"	10,000	AF6	1/4"	2 1/8"

Taper Seal Valves

Line Filters

The line filters as shown utilize sintered stainless steel filter discs (AF2 & AF1 – 3 pc./set, AF4 & AF6 – 4 pc./set). Porosities are available as per the chart to the right. If not otherwise specified, 100 micron filter discs are supplied. (One micron = 0.001 millimeters). Material of bodies and end covers is high tensile 316 stainless steel. Standard glands and sleeves are provided unless otherwise specified.

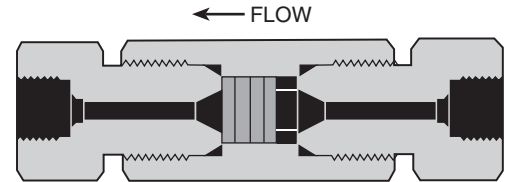

Catalog No.	Pressure Rating psi	Connections	Length	Hex Size	Micron Size Filter Available					
					0.5	2	5	10	40	100
15-51AF1	15,000	1/16" TAPER SEAL	3 1/8"	3/4"	●	●	●	●	●	●
15-51AF2	15,000	1/8" TAPER SEAL	3 1/8"	3/4"	●	●	●	●	●	●
10-51AF4	10,000	1/4" TAPER SEAL	5 1/4"	1 3/8"	●	●	●	●	●	●
10-51AF6	10,000	3/8" TAPER SEAL	5 1/4"	1 3/8"	●	●	●	●	●	●

Ball Check Valves

Ball type check valves insure flow in one direction only. Material for bodies, balls, and covers is high tensile 316 stainless steel. Standard tubing glands and sleeves are provided unless otherwise specified.

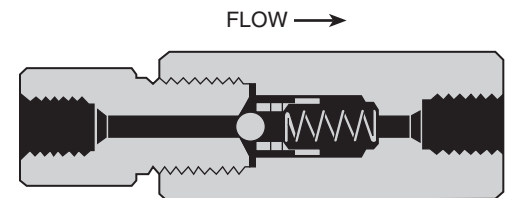

Catalog No.	psi	Connections	Length	Hex
15-41AF1	15,000	1/16" TAPER SEAL	3 1/8"	1"
15-41AF2	15,000	1/8" TAPER SEAL	3 9/16"	1"
10-41AF4	10,000	1/4" TAPER SEAL	3 7/8"	1"
10-41AF6	10,000	3/8" TAPER SEAL	3 7/8"	1"

Soft Seat Check Valves

Soft seat check valves insure flow in one direction only and can be mounted in any position. These are highly reliable for both gas and liquid service. Standard O-ring (soft seat) material for the sealing surface is Buna-N (nitrile) with other materials including Teflon and Viton available on request. Temperature is limited by the choice of O-ring material. Material of all other parts is high tensile 316 stainless steel. Standard glands and sleeves are provided unless otherwise specified.

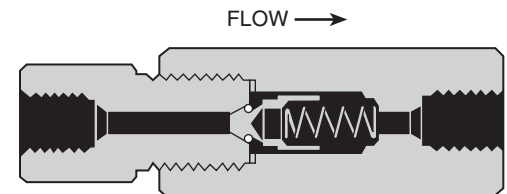

Catalog No.	psi	Connections	Length	Hex
15-41AF1-T	15,000	1/16" TAPER SEAL	3 1/2"	1"
15-41AF2-T	15,000	1/8" TAPER SEAL	3 1/2"	1"
10-41AF4-T	10,000	1/4" TAPER SEAL	3 7/8"	1"
10-41AF6-T	10,000	3/8" TAPER SEAL	3 7/8"	1"

Safety Heads

A choice of three safety head designs is available: male inlet, female inlet (straight), and tee type. The male inlet design can be inserted directly into the tubing connections of valves and various fittings such as tees and crosses, or located in pressure vessels.

Outlet connections on all sizes are $\frac{3}{8}$ " pipe (NPT). This outlet may be connected to a suitable discharge line to vent pressure to a safe location in the event of bursting of the rupture disc. Torque required for sealing rupture discs will range from 40 to 60 foot pounds, depending upon pressure and media being used.

Material of bodies and hold down nuts is high tensile 316 stainless steel. Hold down rings are hardened 17-4PH stainless steel. Standard tubing glands and collars (sleeves) are provided unless otherwise specified.

Note: Rupture discs are **not** included and must be ordered as a separate item.

CE marked safety heads are now available, add -CE to end of standard part number. Consult factory for pricing.

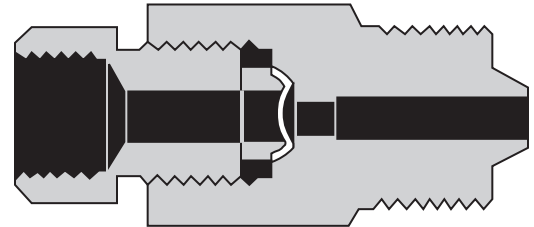

2

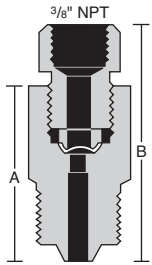

Male Inlet Safety Heads

Catalog No.	Pressure Rating psi	Inlet Connection	A	B	Hex Size
15-61AM2	15,000	$\frac{1}{8}$ " TAPER SEAL	$1\frac{7}{8}$ "	$2\frac{15}{16}$ "	1"
10-61AM4	10,000	$\frac{1}{4}$ " TAPER SEAL	$2\frac{1}{2}$ "	$2\frac{7}{16}$ "	1"
10-61AM6	10,000	$\frac{3}{8}$ " TAPER SEAL	$2\frac{1}{2}$ "	$2\frac{7}{16}$ "	1"

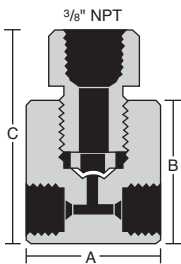

Tee Type Safety Heads

Catalog No.	Pressure Rating psi	Inlet Connection	A	B	C
15-63AF1	15,000	$\frac{1}{16}$ " TAPER SEAL	$1\frac{1}{8}$ " HEX	$1\frac{3}{4}$ "	$2\frac{3}{4}$ "
15-63AF2	15,000	$\frac{1}{8}$ " TAPER SEAL	$1\frac{1}{2}$ "	$1\frac{1}{2}$ "	$2\frac{1}{2}$ "
10-63AF4	10,000	$\frac{1}{4}$ " TAPER SEAL	2"	$1\frac{3}{4}$ "	$2\frac{7}{8}$ "
10-63AF6	10,000	$\frac{3}{8}$ " TAPER SEAL	2"	$1\frac{3}{4}$ "	$2\frac{7}{8}$ "

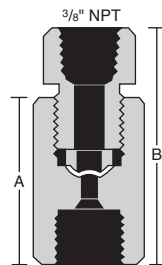

Female Inlet (Straight) Safety Heads

Catalog No.	Pressure Rating psi	Inlet Connection	A	B	Hex Size
15-61AF1	15,000	$\frac{1}{16}$ " TAPER SEAL	$1\frac{7}{8}$ "	$2\frac{15}{16}$ "	1"
15-61AF2	15,000	$\frac{1}{8}$ " TAPER SEAL	$1\frac{7}{8}$ "	$2\frac{15}{16}$ "	1"
10-61AF4	10,000	$\frac{1}{4}$ " TAPER SEAL	$1\frac{7}{8}$ "	$2\frac{15}{16}$ "	1"
10-61AF6	10,000	$\frac{3}{8}$ " TAPER SEAL	$1\frac{7}{8}$ "	$2\frac{15}{16}$ "	1"

Taper Seal Valves

Rupture Discs

1/4" Angled Seat

2

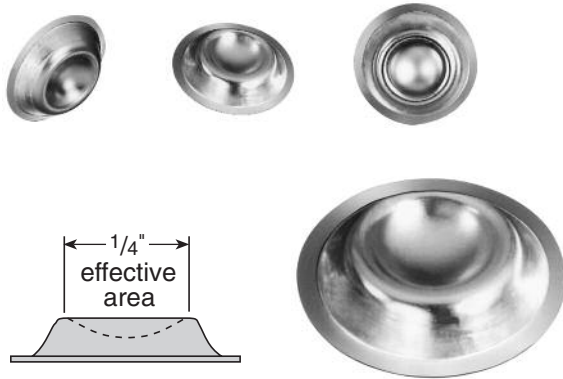

Standard rupture discs are available from stock in burst pressures as listed in the chart below. Taper seal pressures are shaded. These discs are 316 stainless steel (except for 1000 psi which are inconel) and may be used with any of the safety heads shown. Note that these rupture discs are supplied with a range of plus 6% and minus 3% of specified burst pressure. Samples of each batch are then tested and typically the actual average burst pressure is stamped on an accompanying metal tag. There is a +/- 5% burst tolerance applied after the burst pressure has been established. Factors influencing rupture disc life include corrosion, metal fatigue, and cyclic effects. Periodic replacement is recommended to prevent premature failure.

SPECIAL DISCS are available on special order for pressure ranges not shown below and in numerous materials and coatings. Consult factory for price and delivery.

Standard Burst Pressures (in psi at 72°F)

1,000	3,000	5,000	7,000	9,000	11,000	17,500	25,000	37,500	55,000
1,500	3,500	5,500	7,500	9,500	11,500	18,000	27,000	40,000	60,000
2,000	4,000	6,000	8,000	10,000	12,500	20,000	30,000	45,000	65,000
2,500	4,500	6,500	8,500	10,500	15,000	22,500	35,000	50,000	

Taper Seal Tubing

Tubing is cold drawn, seamless, and is supplied in the 1/8 hard condition (not annealed). Tensile strength is approximately 40 percent higher than that of annealed tubing. All tubing is manufactured in strict accordance with High Pressure Equipment Company specifications to insure tolerances and bore quality. Tubing is stocked in lengths of 20 to 24 feet but may be ordered in shorter lengths with **no additional cutting charge**.

Note: The 1/16" and 1/8" O.D. tubing sizes may be coiled for shipment. Larger sizes must be shipped in straight lengths.

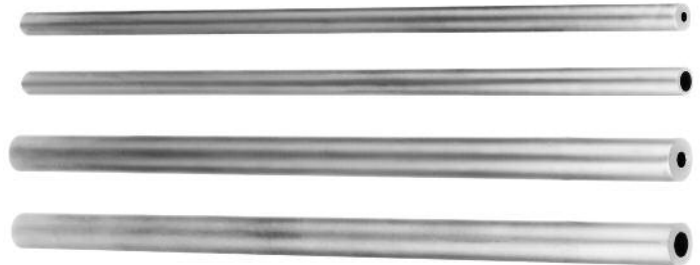

	Tubing Size	Working Pressure psi	Type of Connection Used	Material	Wall Thickness	Catalog Order Number
1/16"	1/16" O.D. x 0.006" I.D.	15,000	1/16" TAPER SEAL (AF1)	316 SS	.028	15-9A1-006
	1/16" O.D. x 0.030" I.D.				.016	15-9A1-030
1/8"	1/8" O.D. x 0.060" I.D.	15,000	1/8" TAPER SEAL (AF2)	316 SS	.032	15-9A2
				Hastelloy-C	.032	15-9A2-HC276
1/4"	1/4" O.D. x 1/8" I.D.	10,000	1/4" TAPER SEAL (AF4)	316 SS	.062	10-9A4-316
				304 SS	.062	10-9A4-304
3/8"	3/8" O.D. x 1/4" I.D.	10,000	3/8" TAPER SEAL (AF6)	316 SS	.062	10-9A6-316

Taper Seal Connections 10,000 and 15,000 psi service

Taper Seal connections are available for $\frac{1}{16}$ ", $\frac{1}{8}$ ", $\frac{1}{4}$ ", and $\frac{3}{8}$ " O.D. tubing. No special tubing preparation is required – simply cut tubing to desired length, deburr and assemble.

The $\frac{1}{8}$ ", $\frac{1}{4}$ ", and $\frac{3}{8}$ " sizes utilize a two-piece sleeve which is supplied partially assembled. When the connection is assembled, the outer sleeve portion is permanently compressed over the inner portion to rigidly lock the sleeve onto the tubing. Note that the sleeve is not forced to bite into the tubing, but rather is clamped onto the tubing much like a machine collet.

Pressure ratings.

The $\frac{1}{16}$ " and $\frac{1}{8}$ " O.D. tubing size connections are rated to 15,000 psi working pressure. The $\frac{1}{4}$ " and $\frac{3}{8}$ " O.D. sizes are rated to 10,000 psi working pressure.

Easy make-up connections.

One of the popular benefits of taper seal connections is that it is very easy to determine when the connection is "tight enough" during initial assembly. Simply rotate the tubing gland into the connection until you feel a "bottoming out" or "dead stop" of the wrench. This signals that the connection has been properly made.

A commercial thread lubricant is highly recommended to facilitate initial makeup of the connection, but such lubrication may be removed afterwards if desired. The Taper Seal connection can be disassembled and then reassembled an indefinite number of times.

Standard material for the gland is Type 316 stainless steel. The inner portion of the two-piece sleeve is Type 316 stainless steel. The non-wetted outer sleeve portion is zinc plated alloy steel. (Note that the $\frac{1}{16}$ " O.D. size is a one-piece sleeve design) in Type 316 stainless steel.

Tubing glands and sleeves are provided with all valves and fittings unless otherwise requested. (See chart at right for size details and catalog numbers).

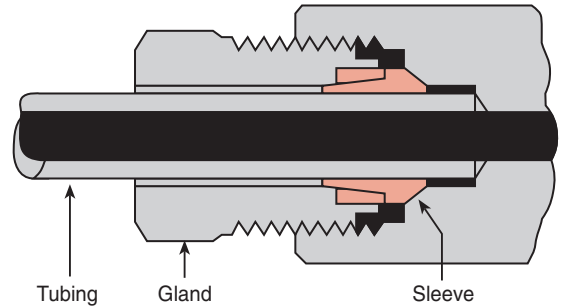

2

	15,000 psi		10,000 psi	
	AF1 1/16" O.D. Tubing	AF2 1/8" O.D. Tubing	AF4 1/4" O.D. Tubing	AF6 3/8" O.D. Tubing
Female Opening Detail				
Gland				
Sleeve				
Plug				

Taper Seal Valves

Taper Seal Assembly Procedure – AF2, AF4 and AF6 Connections

2

1. Lubricate the male threads of the Taperseal gland, and the back of the outer collar on the sleeve with a process compatible lubricant.
2. Put a small amount of lubricant on the area where the outer collar and inner sleeve come in contact with each other. This will reduce the friction when the outer collar slides over the inner sleeve.
3. Assemble the Taperseal gland, sleeve and tubing into the component or assembly mandrel and tighten finger-tight.
4. Using the appropriate size wrench, rotate the gland nut clockwise one half turn and stop. Back off the gland nut and repeat this step approximately 3 – 4 times until the gland stops rotating or “bottoms out”. Do not rotate the gland nut continuously clockwise or galling between the outer collar and inner sleeve may occur.
5. Remove the tube with the gland and sleeve attached, and inspect the sleeve assembly to be sure the outer collar has slid completely down over the inner sleeve. No gaps should be present.
6. Refer to page 142 of the Technical Information Section of our catalog for Recommended Torque / Tubing Connections. Torque the tubing gland to the value listed on the chart.
7. Refer to the catalog page 17 for proper connection diagram and component details.
 - Please note that a mandrel can be used to properly make-up the connection rather than using the actual component. Using the mandrel will prevent any galling of the female component threads. Mandrels can be purchased from HiP.



Correctly Assembled Taper Seal Connection



Incorrect Assembly

Packing Options

Taper Seal

Material	Part Number		
	AF1	AF2	AF4/ AF6
Teflon*	B-195	B-195	B-181
Grafoil	B-1379	B-1379	B-1417
Buna-N	B-101	B-101	B-102
Viton	B-614	B-614	B-849
Silicone	B-149	B-149	B-147